

**International  
Progress Report**

**IPR-04-51**

**Äspö Hard Rock Laboratory**

**Status Report  
July - September 2004**

Svensk Kärnbränslehantering AB

December 2004

**Svensk Kärnbränslehantering AB**

Swedish Nuclear Fuel  
and Waste Management Co  
Box 5864  
SE-102 40 Stockholm Sweden  
Tel 08-459 84 00  
+46 8 459 84 00  
Fax 08-661 57 19  
+46 8 661 57 19



**Äspö Hard Rock  
Laboratory**

Report no.  
IPR-04-51

Author  
Karin Pers  
(comp.)

Checked by

Approved  
Christer Svemar

No.  
F50K  
Date  
December 2004

Date

Date  
2004-12-15

# Äspö Hard Rock Laboratory

## Status Report July – September 2004

Svensk Kärnbränslehantering AB

December 2004

*Keywords:* Äspö HRL, Status Report

This report concerns a study which was conducted for SKB. The conclusions and viewpoints presented in the report are those of the author(s) and do not necessarily coincide with those of the client.

# Overview

The Äspö Hard Rock Laboratory (HRL) constitutes an important part of SKB's work to design and construct a deep geological repository for spent nuclear fuel and to develop and test methods for characterisation of a suitable site.

The plans for SKB's research and development of technique during the period 2002–2007 are presented in SKB's RD&D-Programme 2001 /SKB, 2001/. The information given in the RD&D-Programme related to Äspö HRL is annually detailed in the Äspö HRL Planning Report /SKB, 2004/.

This Äspö HRL Status Report is a collection of the main achievements obtained during the third quarter 2004.

## **Technology**

One of the goals for Äspö HRL is to demonstrate technology for and function of important parts of the repository system. This implies translation of current scientific knowledge and state-of-the-art technology into engineering practice applicable in a real repository. A number of large-scale field experiments are therefore conducted at Äspö HRL: Canister Retrieval Test, Prototype Repository, Backfill and Plug Test, Long Term Test of Buffer Material, Cleaning and sealing of investigation boreholes, Injection grout for deep repositories, KBS-3 method with horizontal emplacement, Large Scale Gas Injection Test, and Temperature Buffer Test.

## **Geo-science**

Geo-scientific research is a natural part of the activities at Äspö HRL. Studies with the major aims to increase the understanding of the rock mass material properties and to increase the knowledge of measurements that can be used in site investigations are important activities: Geological mapping and modelling, Rock stress measurements, Rock creep, Äspö Pillar Stability Experiment, Heat transport, and Seismic influence on the groundwater system.

## **Natural barriers**

Many experiments in Äspö HRL are related to the rock, its properties, and *in situ* environmental conditions. The goals are to increase the scientific knowledge of the safety margins of the deep repository and to provide data for performance and safety assessment. The experiments performed at conditions expected to prevail at repository depth are: Tracer Retention Understanding Experiments (True Block Scale Continuation and True-1 Continuation), Long Term Diffusion Experiment, Radionuclide Retention Experiments, Colloid Project, Microbe Project, and Matrix Fluid Chemistry.

Tests of models for groundwater flow, radionuclide migration and chemical/biological processes are one main purpose of the Äspö HRL. The major project is the Äspö Task Force on Modelling of Groundwater Flow and Transport of Solutes.

### ***Äspö facility***

An important part of the work at the Äspö facility is the administration, operation, and maintenance of instruments as well as development of investigation methods. Other issues are to keep the stationary hydro monitoring system (HMS) continuously available and to carry out the programme for monitoring of groundwater head and flow and the programme for monitoring of groundwater chemistry.

### ***International co-operation***

The Äspö HRL has so far attracted considerable international interest. Seven organisations from six countries participate during 2004 in the co-operation apart from SKB. In addition, SKB takes parts in several EC-projects.

### ***Environmental research***

On the initiative of the Äspö Environmental Research Foundation the University of Kalmar has set up the Äspö Research School. The research school has a special interest in the transport of pollutants and their distribution in rock, ground, water, and biosphere. The research school is co-financed by the municipality of Oskarshamn, SKB, and the University of Kalmar.

# Contents

<b>1</b>	<b>General</b>	<b>4</b>
<b>2</b>	<b>Technology</b>	<b>5</b>
2.1	Canister Retrieval Test	6
2.2	Prototype Repository	7
2.3	Backfill and Plug Test	8
2.4	Long Term Test of Buffer Material	9
2.5	Cleaning and sealing of investigation boreholes	11
2.6	Injection grout for deep repositories	12
2.7	KBS-3 method with horizontal emplacement	13
2.8	Large Scale Gas Injection Test	14
2.9	Temperature Buffer Test	15
2.10	Shearing of canister in deposition hole	16
2.11	Learning from experiences	16
2.12	Task Force on Engineered Barrier Systems	17
<b>3</b>	<b>Geo-science</b>	<b>18</b>
3.1	Geological mapping and modelling	18
3.2	Rock stress measurements	19
3.3	Rock creep	19
3.4	Äspö Pillar Stability Experiment	20
3.5	Heat transport	21
3.6	Seismic influence on the groundwater system	21
<b>4</b>	<b>Natural barriers</b>	<b>22</b>
4.1	Tracer Retention Understanding Experiments	23
4.1.1	True Block Scale Continuation	23
4.1.2	True-1 Continuation	24
4.2	Long Term Diffusion Experiment	25
4.3	Radionuclide Retention Experiments	26
4.4	Colloid Project	28
4.5	Microbe Project	29
4.6	Matrix Fluid Chemistry	31
4.7	Task Force on Modelling of Groundwater Flow and Transport of Solutes	32
4.8	Padamot	34
4.9	Fe-oxides in fractures	35
<b>5</b>	<b>Äspö facility</b>	<b>36</b>
5.1	Facility operation	36
5.2	Hydro Monitoring System	38
5.3	Programme for monitoring of groundwater head and flow	39
5.4	Programme for monitoring of groundwater chemistry	40
<b>6</b>	<b>International co-operation</b>	<b>41</b>
<b>7</b>	<b>Environmental research</b>	<b>43</b>
7.1	Äspö Research School	43
<b>8</b>	<b>Documentation</b>	<b>44</b>
8.1	Äspö International Progress Reports	44
8.2	Technical Documents and International Technical Documents	45
<b>9</b>	<b>References</b>	<b>46</b>

# 1 General

The Äspö Hard Rock Laboratory (HRL) constitutes an important part of SKB's work to design and construct a deep geological repository for spent nuclear fuel and to develop and test methods for characterisation of a suitable site.

One of the fundamental reasons behind SKB's decision to construct an underground laboratory was to create an opportunity for research, development and demonstration in a realistic and undisturbed rock environment down to repository depth. The underground part of the laboratory consists of a tunnel from the Simpevarp peninsula to the southern part of Äspö where the tunnel continues in a spiral down to a depth of 460 m. The rock volume and the available underground excavations have to be divided between all the experiments performed at the Äspö HRL. In Figure 1-1 the allocation of the experimental sites in Äspö HRL are shown.

The Äspö HRL and the associated research, development, and demonstration tasks, managed by the Repository Technology Department within SKB, have so far attracted considerable international interest.

SKB's overall plans for research, development, and demonstration during the period 2002–2007 are presented in SKB's RD&D-Programme 2001 /SKB, 2001/. The planned activities related to Äspö HRL are detailed on a yearly basis in the Äspö HRL Planning Report. The role of the Planning Report is also to present the background and objectives of each experiment and activity. This Status Report concentrates on the work in progress and refers to the Planning Report /SKB, 2004/ for more background information. The Annual Report will in detail present and summarise new findings and results obtained during the present year.

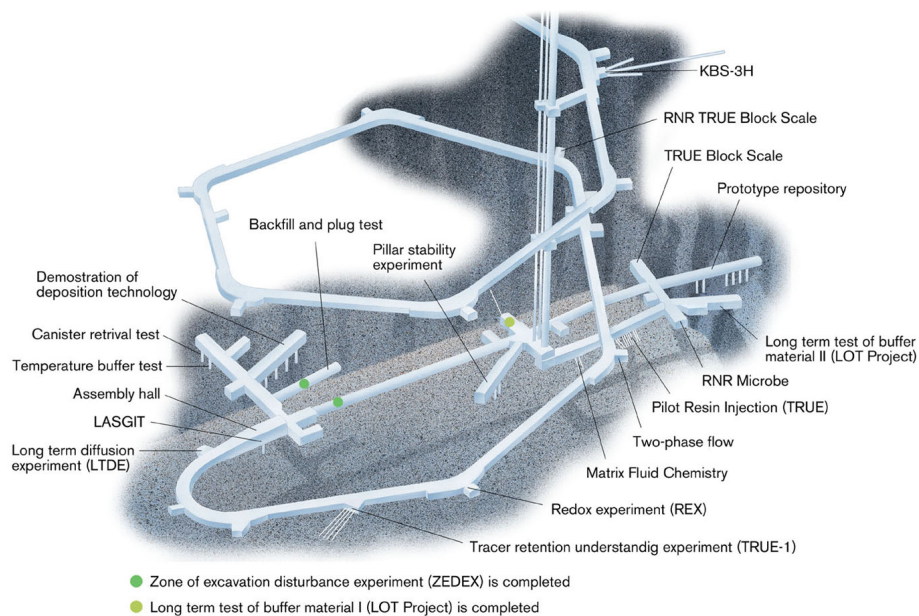

**Figure 1-1** Allocation of experimental sites in Äspö HRL from -220 m to -450 m level.

## 2 Technology

One of the goals for Äspö HRL is to demonstrate technology for and function of important parts of the repository system. This implies translation of current scientific knowledge and state-of-the-art technology into engineering practice applicable in a real repository.

It is important that development, testing and demonstration of methods and procedures, as well as testing and demonstration of repository system performance, are conducted under realistic conditions and at appropriate scale. A number of large-scale field experiments and supporting activities are therefore conducted at Äspö HRL, see Figure 2-1. The experiments focus on different aspects of engineering technology and performance testing, and will together form a major experimental programme.



*Figure 2-1 Handling of full size bentonite blocks in Äspö HRL.*

## 2.1 Canister Retrieval Test

---

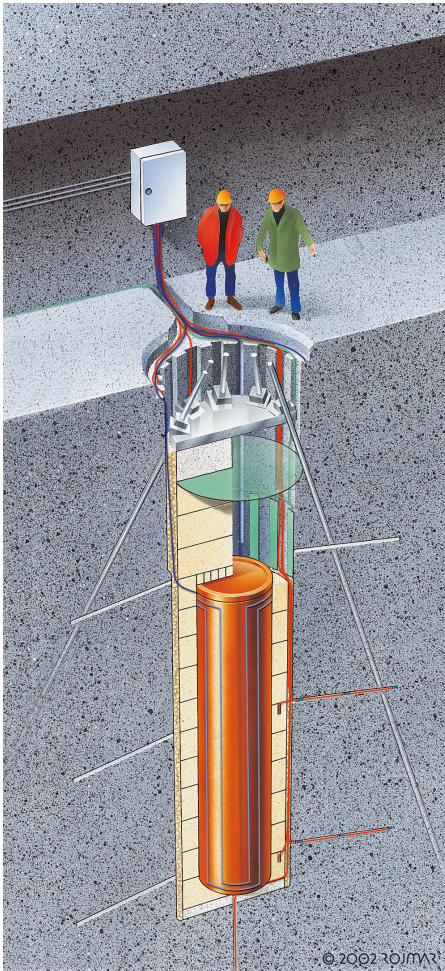

The Canister Retrieval Test is aiming at demonstrating the readiness for recovering of emplaced canisters also after the time when the bentonite is fully saturated.

In the Canister Retrieval Test two full-scale deposition holes have been drilled for the purpose of testing technology for retrieval of canisters after the buffer has become saturated.

These holes have been used for studies of the drilling process and the rock mechanical consequences of drilling the holes.

Canister and bentonite blocks were emplaced in one of the holes in 2000 and the hole was sealed with a plug, heater turned on and artificial water supply to saturate the buffer started.

The test has been running for almost four years with continuous measurements of the wetting process, temperature, stresses, and strains.

---

### **Achievements**

The artificial water supply to the bentonite has continued and the water pressure in the mats that distribute the water has been maintained at 800 kPa during the entire reporting period. The filters in the mats were back-flushed in August in order to avoid clogging.

The measurements of a large number of parameters to study the THM-processes and to provide a basis for e.g. modelling purposes have continued. A data report covering the period up to 1<sup>st</sup> of May 2004 /Goudarzi *et al.*, 2004a/ is available. Modelling of pressure, water content etc in the buffer during the saturation process is in progress although delayed. The saturation time for the 350 mm thick buffer along the canister was predicted to 2-3 years and to 5-10 years in the buffer below and above the canister. The relative humidity sensors indicate that the bentonite between the rock and the canister is now close to water saturation although the wetting still seems to be somewhat uneven.



## 2.2 Prototype Repository

---



The Prototype Repository is located in the TBM-tunnel at the -450 m level and includes six full scale deposition holes. The aims of the Prototype Repository are to demonstrate the integrated function of the repository components and to provide a full-scale reference for comparison with models and assumptions.

The Prototype Repository should, to the extent possible, simulate the real deep repository system regarding geometry, materials, and rock environment.

Instrumentation is used to monitor processes and properties in the canister, buffer material, backfill, and the near-field rock. The evolution will be followed for a long time.

The inner tunnel (Section I) was installed and the plug cast in 2001 and the heaters were turned on one by one. The outer tunnel (Section II) was backfilled in June 2003 and the tunnel plug with two lead-throughs was casted in September the same year.

---

### **Achievements**

The data collection system comprises temperature, total pressure, pore water pressure, relative humidity and resistivity measurements in buffer and backfill, as well as temperature and water pressure measurements in boreholes in the rock around the tunnel. The collection of data is in progress and data report No. 10 covering the period up to 1<sup>st</sup> of June 2004 is printed /Goudarzi and Johannesson, 2004/. Overhauling of the data acquisition system is in progress and hydraulic tests of the rock mass have been done.

## 2.3 Backfill and Plug Test

---

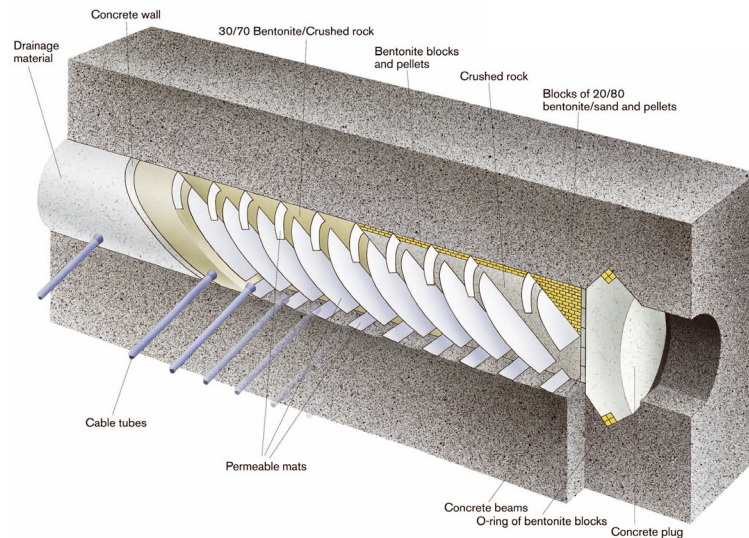

The Backfill and Plug Test includes tests of backfill materials and emplacement methods and a test of a full-scale plug. The inner part of the tunnel is filled with a mixture of bentonite and crushed rock (30/70) and the outer part is filled with crushed rock and bentonite blocks and pellets at the roof.

The integrated function of the backfill material and the near-field rock in a deposition tunnel

excavated by blasting is studied as well as the hydraulic and mechanical functions of the full-scale concrete plug.

The entire test set-up with backfill, instrumentation and casting of the plug was finished in the end of September 1999 and the wetting of the 30/70 mixture through the filter mats started in late 1999. Wetting of the backfill has continued since then.

---

### **Achievements**

Water saturation, water pressure and swelling pressure in the backfill and water pressure in the surrounding rock have been continuously measured and registered according to plan and a data report covering the period up to 1<sup>st</sup> of January 2004 /Goudarzi *et al.*, 2004b/ is available.

Flow testing of the backfill materials has continued and the strategy for the testing is in the first stage to successively decrease the water pressure in the mat sections (each section comprises three mats) starting with the mats at the plug. The flow testing has continued. The hydraulic gradient has been moved to section A3 backfilled with a mixture of crushed rock and bentonite (30/70), see Figure 2-2. The water flow caused by the difference in water pressure between 500 kPa and 400 kPa has been measured and the hydraulic conductivity of the backfill in the measured section is presently being evaluated.

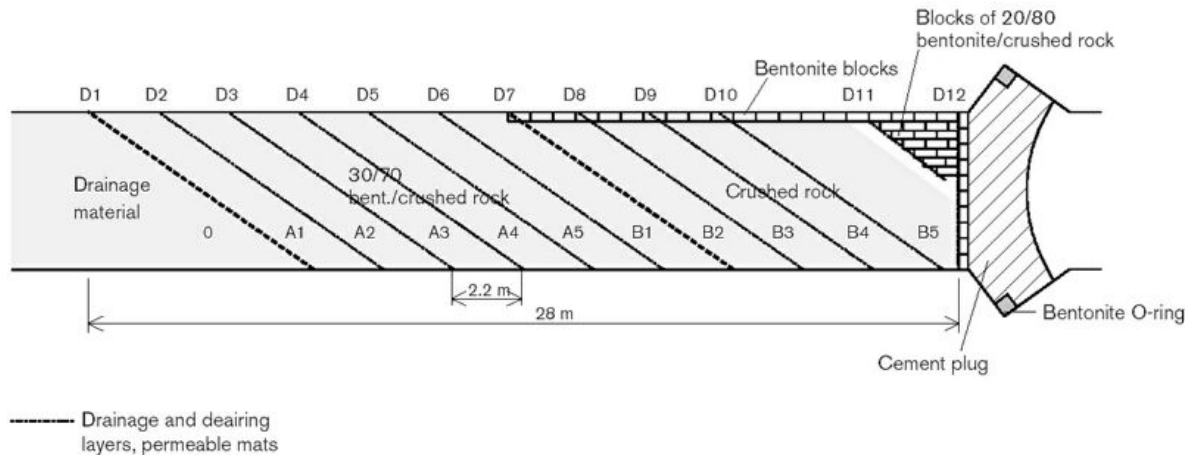

**Figure 2-2** Layout of the Backfill and Plug Test showing the numbering of the backfill sections and permeable mats.

## 2.4 Long Term Test of Buffer Material

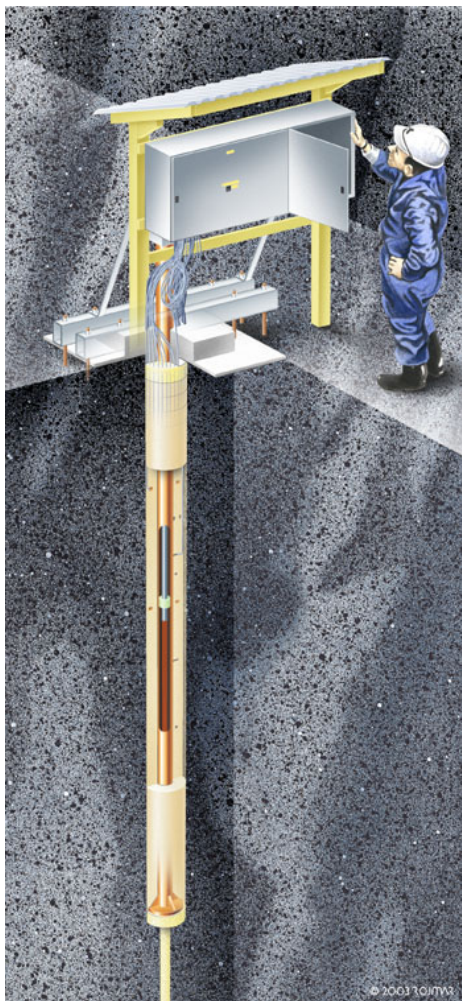

The Long Term Test of Buffer Material aims to validate models and hypotheses concerning mineralogy and physical properties in a bentonite buffer.

Five 300 mm diameter test holes with a depth around 4 m have been drilled and instrumented. Five test parcels were installed in 1999. The intended test temperatures of 90°C and 130°C have been reached. In 2001 a one-year parcel was extracted from the rock by overlapping core drilling. The remaining four long term test parcels are functioning well.

The test parcels are also used to study related processes such as bentonite diffusion properties, microbiology, copper corrosion and gas transport in buffer material under conditions similar to those expected in a repository.

## Achievements

The analysing work and testing with material from the extracted one-year parcel A0 (see Table 2-1) is completed. The compilation of results is in progress and a technical report will be issued. The results from the A0 parcel are used for modelling of the chemical and mineralogical evolution in the buffer. The modelling is performed with a transport code coupled with a geochemical code (Phast) and aims at improving previous modelling by taking the prevailing temperature gradient into account.

The remaining four long term test parcels have functioned well and temperature, total pressure, water pressure, and water content are continuously measured and registered every hour. The monthly checks of the collected data have been done. The next extraction of a parcel is expected to take place in spring 2005.

**Table 2-1 Test series for the Long Term Test of Buffer Material.**

Type	No.	max T (°C)	Controlled parameter	Time (years)	Remark
A	1	130	T, [K+], pH, am	1	Reported
A	0	120-150	T, [K+], pH, am	1	Analysed
A	2	120-150	T, [K+], pH, am	5	On-going
A	3	120-150	T	5	On-going
S	1	90	T	1	Reported
S	2	90	T	5	On-going
S	3	90	T	>>5	On-going

A = adverse conditions

S = standard conditions

T = temperature

[K+] = potassium concentration

pH = high pH from cement

am = accessory minerals added

## 2.5 Cleaning and sealing of investigation boreholes

---

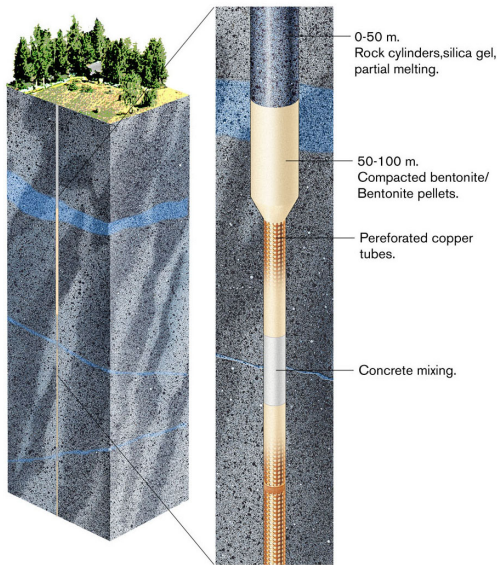

A project, with the aim to identify and demonstrate the best available techniques for cleaning and sealing of investigation boreholes, was initiated in 2002.

The project comprises two phases. Phase 1 was mainly an inventory of available techniques, and Phase 2 aims to develop a complete cleaning and sealing concept and to demonstrate it.

A laboratory test program on candidate sealing materials is part of the project. Short and long boreholes from the surface and from tunnels underground, will be used to demonstrate the plugging concept.

The project is run in co-operation between SKB and Posiva.

---

### **Achievements**

The first phase of the project is completed and the major conclusion was that smectite clay is recommended as main candidate material for sealing of boreholes in the forthcoming work. The second phase focuses on the development of a complete concept for cleaning and sealing of boreholes. The present design for the borehole seals consists of cylindrical pre-compacted clay blocks contained in perforated copper tubes that are jointed in conjunction with insertion into the boreholes.

One part of the project is a full-scale field test at Äspö where two deep candidate investigation boreholes, KAS06 and KAS07, are being investigated as a preparation for the field test. Unfortunately the TV-logging of the two boreholes did not succeed since the camera did not pass the cone at 100 meter level.

The laboratory studies of material for plugging boreholes are continued at Clay Technology AB and CBI (Swedish cement and concrete research institute). Manufacturing of copper tube for field testing have been ordered and the planning for field testing is in progress.

A draft version of a final report of the complete concept has been prepared and was presented and discussed at a symposium in Stockholm on 24<sup>th</sup> of September.

## 2.6 Injection grout for deep repositories

### SAFETY ASSESSORS' VIEW ON pH

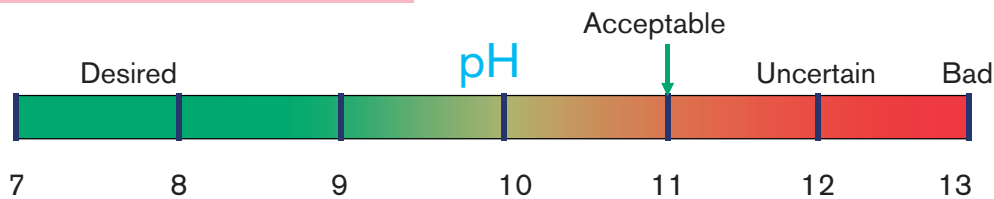

### PRINCIPLES FOR pH-EVOLUTION OF STANDARD CEMENT

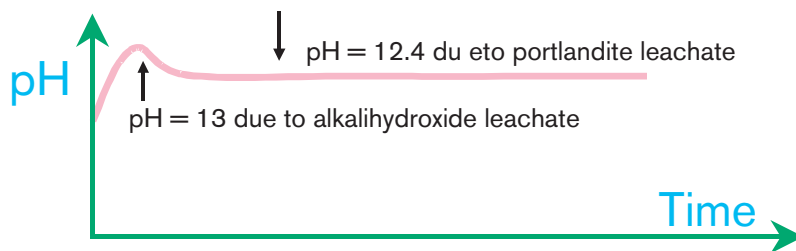

The use of low-pH products in the deep repository will probably be necessary in order to get leachates with a sufficiently low pH ( $\leq 11$ ). A project concerning the use of low-pH cementitious products started in 2001 as a co-operation between SKB, Posiva, and NUMO.

The test to be carried out at the Äspö HRL is part of SP4 – Field testing in Sweden. The sub-project comprises injection field tests with Silica Sol and the aim is to test if it penetrates into small fractures ( $< 100 \mu\text{m}$ ). The proposed test site is a rock pillar at the tunnel TASM, section 0/670.

The present objectives of the project are to achieve quantified, tested and approved low-pH injection grouts. The project is divided into four sub projects:

- SP1 Low-pH cementitious injection grout for larger fractures.
- SP2 Non-cementitious low-pH injection grout for smaller fractures.
- SP3 Field testing in Finland.
- SP4 Field testing in Sweden

### **Achievements**

Preparations of the site prior to the grouting test were initiated already in 2003 and hydraulic pre-tests were carried out at the site in February. Grouting test with silica sol, was performed in March and a minimum grout spread of 0.4 m was observed in an adjacent hole. The grouting was followed up by complementary hydraulic testing during May. The hydraulic tests showed a sealing efficiency of 70 % in the affected rock mass. Thereafter cores from the site will be characterised by visual observations to verify if grout has spread.

## 2.7 KBS-3 method with horizontal emplacement

---

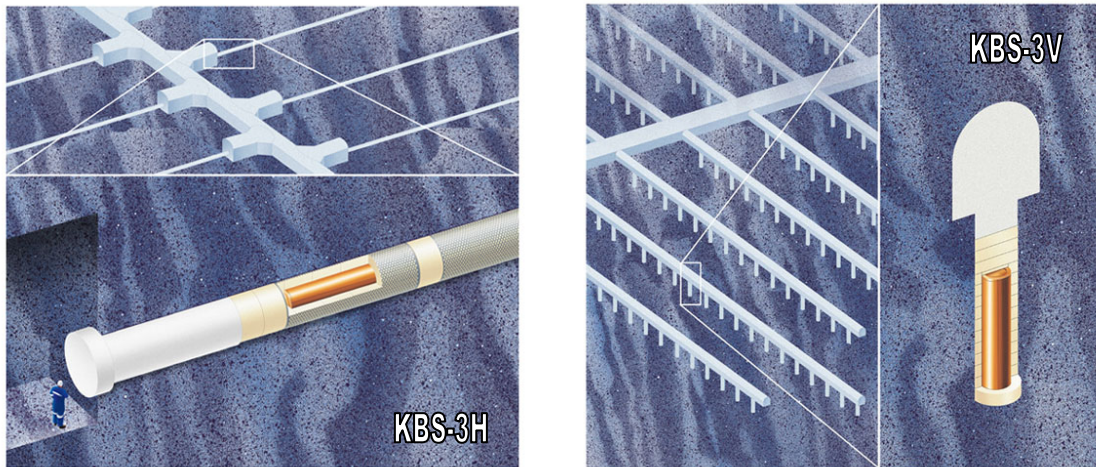

The possibility to modify the reference KBS-3 method and make serial deposition of canisters in long horizontal deposition holes (KBS-3H), instead of deposition of single canisters in vertical deposition holes (KBS-3V), is studied in this project.

One reason for proposing the change is that the deposition tunnels in KBS-3V are not needed if the canisters are disposed in long horizontal deposition holes and the excavated rock volume and the amount of backfill can be considerably reduced. This in turn reduces the environmental impact during the construction of the repository and also the construction costs.

---

### **Achievements**

The site for the demonstration of the method is located at 220 m depth in Äspö HRL. A niche, with a height of about 8 m and a bottom area of 25 x 15 m that will form the work area, has been excavated. A concrete foundation has been casted in the niche and a wall foundation which is necessary for the start of the excavation has been prepared. In addition, preparation for easier movement along the drilling area has been undertaken.

The plan is to excavate two horizontal deposition holes, one with a length of 15 metres and one with a length of 95 metres. Originally, three horizontal holes were planned. It has been decided that the deposition holes will be excavated by blind horizontal raise boring and that the straightness of the pilot hole will be guaranteed by the use of active steering. The contractor has modified the drilling equipment and the active steering system is being prepared. A start meeting was held at Äspö in August and the drilling contractor started their work at site in the end of September.

The barrier performance of the KBS-3H concept is studied by Posiva and the reporting is in progress. Laboratory tests of the buffer behaviour performance are carried out by Clay Technology to study occurrence of erosion and piping in the buffer as well as in the distance blocks. Tests are performed both in scale of 1:10 and full scale. The test program has been finalised. A summary report of the buffer research is being prepared.

## 2.8 Large Scale Gas Injection Test

---

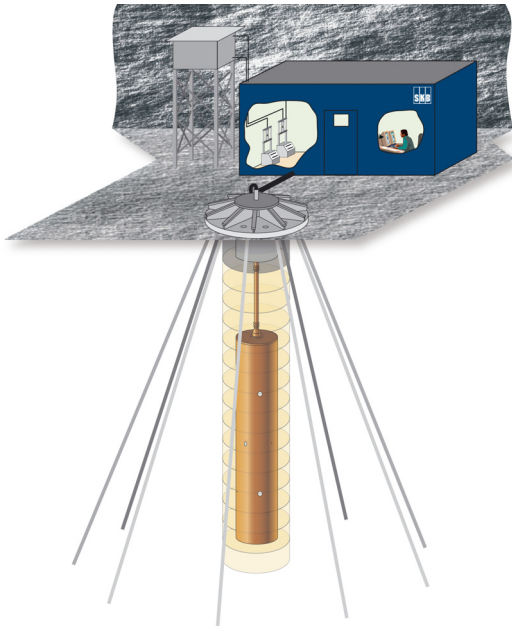

A full-scale canister (without heaters) and a bentonite buffer will be installed in an available bored deposition hole in Äspö HRL. Water will be artificially supplied to the buffer at isothermal conditions.

When the buffer is fully saturated gas injection will start, first with small gas volumes and finally with volumes corresponding to gas formation from a defect full-size canister.

SKB has during several years performed a number of experiments with gas injection on MX-80 bentonite. Today, there is a relatively good understanding of the processes determining the gas transport. One remaining question is, however, the importance of the scale. All bentonite experiments so far have been performed in the centimetre scale and the extrapolation of the results from these experiments to repository scale is unclear. Therefore, the Large Scale Gas Injection Test (Lasgit) has been initiated.

The major aims of the project are to:

- Perform and evaluate full-scale gas injection tests based on the KBS-3 concept.
- Answer questions related to up-scaling.
- Get additional information on gas-transport processes.
- Obtain high quality data for testing and validation of models.
- Demonstrate that gas formation in a canister do not have obvious negative consequences for the repository barriers.

---

### **Achievements**

The test will take place in an existing deposition hole (DA3147G01) in the TBM tunnel. The information available on the hole is sufficient and no new characterisation is planned. The preparations for the installation of the test are in progress.

A workshop was held at Äspö on the 9<sup>th</sup> of August 2004, which resulted in a list of questions to be answered and solved as soon as possible. In addition, an international project meeting was held in the end of August. The main issues discussed at this meeting were the present situation for the Lasgit site, the commissioning of the gas-laboratory, and the availability of data and information from the experiment.

There is still problem with the leak testing of the canister filters and work is done to find a solution to the problems. The leak testing is delayed about seven weeks which means a considerable delay for the project. The estimated time to start the wetting of the buffer (hydration phase) is in the end of November.



## 2.9 Temperature Buffer Test



The French organisation Andra carries out the Temperature Buffer Test (TBT) at Äspö HRL in co-operation with SKB.

The aims of the TBT are to evaluate the benefits of extending the current understanding of the THM behaviour of engineered barriers during the water saturation transient to include high temperatures, above 100°C, and the experimental resources needed to achieve this.

The scientific background to the project relies on results from large-scale field tests on EBS, notably Febex (Grimsel Test Site), Canister Retrieval Test and Prototype Repository (Äspö HRL).

The test is located in the same test area as the Canister Retrieval Test, which is in the main test area at the -420 m level.

The TBT experiment includes two heaters in the axis of the deposition hole, one on top of the other, separated by a compacted bentonite block. They are 3 m long and 610 mm in diameter, and are constructed in carbon steel. Each one simulates a different type of confinement system: a bentonite buffer only (bottom section) and a bentonite buffer with inner sand backfill (upper section).

### **Achievements**

The TBT-test is in the operation and data acquisition phase since March 2003. Two canisters with heaters, bentonite buffer, and sand infilling are installed in the deposition hole together with a system for artificial watering and a large number of sensors and cables for registration of e.g. saturation, pressures, and temperatures. The collection of data is in progress and data report No. 3 covering the period up to 1<sup>st</sup> of April 2004 has been published /Goudarzi *et al.*, 2004c/.

Data acquisition is continuously ongoing and data is reported on a monthly basis. A data link from Äspö to Andra's head office in Paris has been established. Evaluation and predictive modelling are in progress.

The function of the sand filter has been investigated and modified in April and October 2004. Present evaluation modelling addresses the development of stresses in Ring 9 around the upper heater.

## 2.10 Shearing of canister in deposition hole

This project aims at observing the forces that would act on a KBS-3 canister if a displacement of 100 mm would take place in a horizontal fracture that crosses a deposition hole. Such a displacement is considered to be caused by an earthquake, and the test set-up need to provide a shearing motion along the fracture that is equal to an expected shearing motion in real life. The first phase, which will last all of 2004, is a pre-study of design and feasibility. Scoping calculations are assumed to indicate the forces and shearing speed needed and thereby provide the basis for the design of the test set-up.

The *in situ* test set-up is planned to be installed at the site of the Äspö Pillar Stability Experiment when the rock mechanics test has been completed. Two full scale deposition holes then exist with a rock pillar of 1 m in between. One deposition hole will be used for the buffer and canister, while the other deposition hole is used for the shearing equipment.

### **Achievements**

The first phase comprises a pre-study of design and feasibility of the test has started. The results derived were presented at a meeting in Äspö in October, when the design and expected results were shown.

## 2.11 Learning from experiences

In this project, reference techniques for emplacement of buffer, canisters, backfilling, and closure are to be identified. Emplacement of buffer and canisters, and backfilling of tunnels have been experienced in Canister Retrieval Test, Prototype Repository and Backfill and Plug Test. These experiences are documented and the result evaluated with respect to possible improvements as well as limits with respect to water inflows.

The work comprises:

- Compilation of the results from more then ten years of performed engineering experiments in Äspö HRL.
- Compilation and evaluation of experience from emplacement of buffer and canisters, backfilling of tunnels, and estimation of acceptable water inflows for the applied methods.

### **Achievements**

A draft report that describes the large series of experiments related to engineered barrier systems that have been conducted in SKB's underground laboratories and construction sites during the time period 1981 to 2003 is available. The review of the draft report is in progress. The report will be published as an IPR report in Äspö's report series.

## **2.12 Task Force on Engineered Barrier Systems**

The Task Force on Engineered Barrier Systems has been on stand-by as long as the Prototype Repository EC-project was operative, i.e. through the first quarter of 2004. The prioritised work on modelling of THMC-processes in buffer during saturation was conducted within the Prototype Repository EC-project.

A Task Force related meeting on buffer and backfill modelling was held in Lund in March. The participants were modellers representing waste-handling organisations in Europe, Japan and North America. The overall conclusion from the workshop was that modelling of some of the major physical processes in buffers and backfills can be made with sufficient accuracy. A number of important issues for further research in the framework of the Task Force were identified, e.g. prediction of access to water from the bedrock is required for adequate modelling of the hydration of buffers and backfills.

### ***Achievements***

The planning for a Task Force has continued thereafter and resulted in a project having the aim of developing the capability of different codes e.g. coupled THMC modelling including gas migration through saturated bentonite.

A planning meeting for the project was held in Lund on September 28<sup>th</sup> with participation of the Chair to be (Prof. A. Gens from UPC) , the Secretariat to be (Clay Technology) and Christer Svemar. At this meeting, announced codes and Modelling Teams from the interested parties were compiled and the scope of the first kick-off meeting was discussed. The kick-off meeting will be held in Spain on October 28<sup>th</sup> in conjunction with the last Febex EC-project meeting.

## 3 Geo-science

Geo-scientific research is a natural part of the activities at Äspö HRL. Studies with the major aims to increase the understanding of the rock mass material properties and to increase the knowledge of measurements that can be used in site investigations are important activities.

### 3.1 Geological mapping and modelling

This project aims at performing a pre-investigation for developing a new method and system for underground mapping to be used in the construction of a future deep repository. The major reasons to develop a new system for underground mapping are aspects on time required, precision in mapping, traceability and objectivity. A higher degree of objectivity achieved with a more automated method is considered important. Increased traceability means that SKB will have better possibilities to establish the tunnel environment pre-rock support and pre-backfilling, thereby showing foundations for interpretations concerning geology, rock mechanics and tunnel maintenance. At this initial stage, the major objective is to find different alternative techniques that could be used as a base for a new mapping system. Contact has been taken with Posiva, in order to establish a co-operation in finding an efficient system for digital underground mapping.

#### ***Achievements***

A report from the geological mapping of the 71 m long TASQ-tunnel has been completed /Magnor, 2004/. Geological mapping of two of the three deposition holes in TASQ has been performed, DQ0063 and DQ0066. The results have been digitized and fed into the TMS database. Deposition hole DO0010G01 at 420 m depth has been mapped in the traditional way and laser scanned for comparison. A complementary mapping of the drillcore (Boremap) from KG0010B01 has been performed by Geosigma AB.

The work of updating the three dimensional RVS models of Äspö will continue. Data from mapping and modelling of the TASQ-tunnel will be added to the present RVS models. Further improvements in the models will be added as deformation zones and other geological features are established.

An updated rock-name terminology has been established in cooperation with site investigations Oskarshamn and Geological Survey of Sweden. The updated terminology will be used by both Äspö and site investigations Oskarshamn.

The relation between fine-grained granitic dykes and structures at the Äspö HRL has been studied as an undergraduate thesis (Jonsson S). A new thesis has been initiated concerning a NW-SE set of brittle fractures in the Äspö rock volume.

## **3.2 Rock stress measurements**

It is important to know the limitations and shortcomings of different rock stress measurement techniques to be able to make correct assessments of the *in situ* stress field from the measured results. Rock stress measurements with different techniques (bore probe, doorstopper and hydraulic fracturing) have during the years been performed as well as numerical modelling of the stress. The strategy for rock stress measurements will be presented in a report.

### ***Achievements***

A co-operation with Posiva with the objective to quality-assure overcoring data has been initiated.

## **3.3 Rock creep**

The aim with this project is to increase the understanding of the material properties of rock and rock-mass and to develop better conceptual models for the influence of the rock damaged zone and rock creep on rock stability.

### ***Achievements***

A literature study and scooping numerical modelling with a three-dimensional coupled hydromechanical computer code (3Dec) have been performed. The results from the modelling and the literature study will be presented in a report. The literature study is under review.

### 3.4 Äspö Pillar Stability Experiment

---

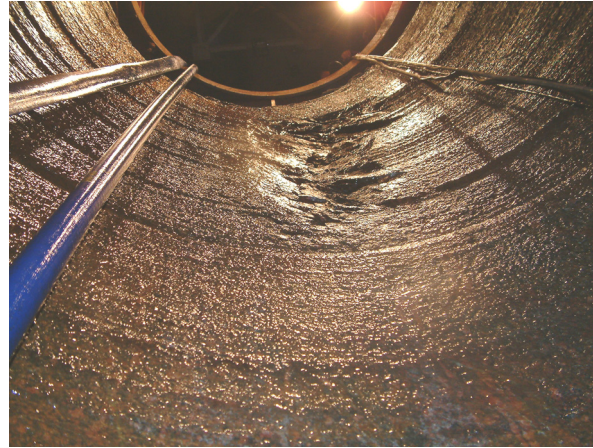
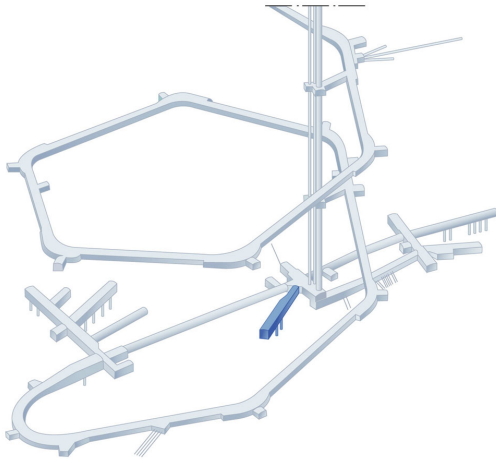

A Pillar Stability Experiment is in progress in Äspö HRL to complement an earlier study performed at URL in Canada. The major aims are to demonstrate the capability to predict spalling in fractured rock mass and the effect of backfill on the propagation of micro cracks.

In addition, the capabilities of two- and three-dimensional mechanical and thermal predictions will be compared.

The pillar is created between two vertical deposition holes drilled in the floor of the tunnel.

The stress in the pillar will be further increased by a thermal load to reach a stress state that induces brittle failure/spalling. One of the boreholes will be subjected to an internal water pressure via a rubber bladder giving a confining pressure of (0.8 MPa).

A new tunnel has been excavated in Äspö HRL to ensure that the experiment is carried out in a rock mass with a virgin stress field. The site is located at the -450 m level. The arched tunnel floor is designed to concentrate the stresses in the centre of it. The arched floor was excavated as a separate bench to minimize the excavation damaged zone in the floor.

---

#### **Achievements**

After the removal of the instruments and the instrument support construction in the hole it was extensively photo documented. The pillar wall was also laser-scanned to get an as good 3D survey of the final deformations as possible. The rock slabs formed was then removed and stored for later analyses. The photograph (above to the right) is taken from the bottom of the hole and up during the removal of the slabs in the lower part of the hole. One can see the many layers of slabs formed during the spalling process. The fractures formed in the deepest part of the notch where curved. The surface of the remaining intact pillar therefore became smooth and the deepest part of the notch rounded. After the removal of the slabs the pillar wall was laser-scanned again to document the final width and depth extent of the spalling.

In late 2004 it is planned to remove the pillar in large blocks. The blocks will be cut with a wire-saw. The pillar has to be de-stressed before the sawing can take place since high stresses are concentrated in it. The plan is to first drill a de-stress slot outside the pillar volume. Extensive numerical modelling has been performed to optimize the slot with regard to geometry and drilling sequence. The changes in the stress path in the pillar during the de-stress drilling is quite complex and can lead to extensive spalling during the early phase of the drilling. The modelling efforts have the objective to make a design that minimizes the risk for more spalling.

### **3.5 Heat transport**

This project is connected to the Prototype Repository the aim is to analyse the thermal properties in different scales and clarify relevant scales for the thermal process around a repository by sensitivity analyses. The work includes inverse modelling of thermal properties, measurements of thermal properties of the rock in different scales and examination of the distribution of thermal conductivities from density loggings. The heat evolution in the Prototype Repository has been monitored since September 2001 and collected thermal data can be seen as a good basis for the Heat transport project. The main topics are:

- Verification of prognosis made on thermal properties in the Prototype Repository by the use of inverse modelling.
- Evaluation of scale dependency of thermal properties and anisotropies by analyses of available density loggings from Äspö HRL, measurements on thermal properties, and inverse modelling.
- Analyses of uncertainties in existing data and the utility of continued data collection.

#### **Achievements**

Three reports dealing with heat transport were completed during 2002 and 2003 /Sundberg, 2002; 2003a; Sundberg *et al.*, 2003/ and a strategy for the thermal model development during site investigations has been presented /Sundberg, 2003b/.

### **3.6 Seismic influence on the groundwater system**

The Hydro Monitoring System (HMS) registers at the moment the piezometric head in 409 positions underground in the Äspö HRL. An induced change of the head with more than 2 kPa triggers an intensive sampling. All measured data are stored in a database.

The data in the database are assumed to bear witness of different seismic activities in Sweden but also abroad, dependent on the magnitude of the event. By analysing the data on changes in the piezometric head at Äspö connections to specific seismic events are expected to be established. In addition, the effects of blasts in Äspö HRL as well as in Clab, during the extension of the underground storage capacity, will be analysed.

#### **Achievements**

Data from the HMS are stored in the database pending analysis. A special computer code is under development that may run and compare the HMS database with other databases, like Sicada or the national seismological database.

## 4 Natural barriers

At the Äspö HRL experiments are performed at conditions that are expected to prevail at repository depth. The experiments are related to the rock, its properties, and *in situ* environmental conditions. The goals are to increase the scientific knowledge of the safety margins of the deep repository and to provide data for performance and safety assessment and thereby clearly present the role of the geosphere for the barrier functions: isolation, retardation and dilution. Processes that influence migration of species along a natural rock fracture are shown Figure 4-1.

Tests of models for groundwater flow, radionuclide migration and chemical/biological processes are one of the main purposes of the Äspö HRL. The programme includes projects with the aim to evaluate the usefulness and reliability of different models and to develop and test methods for determination of parameters required as input to the models.

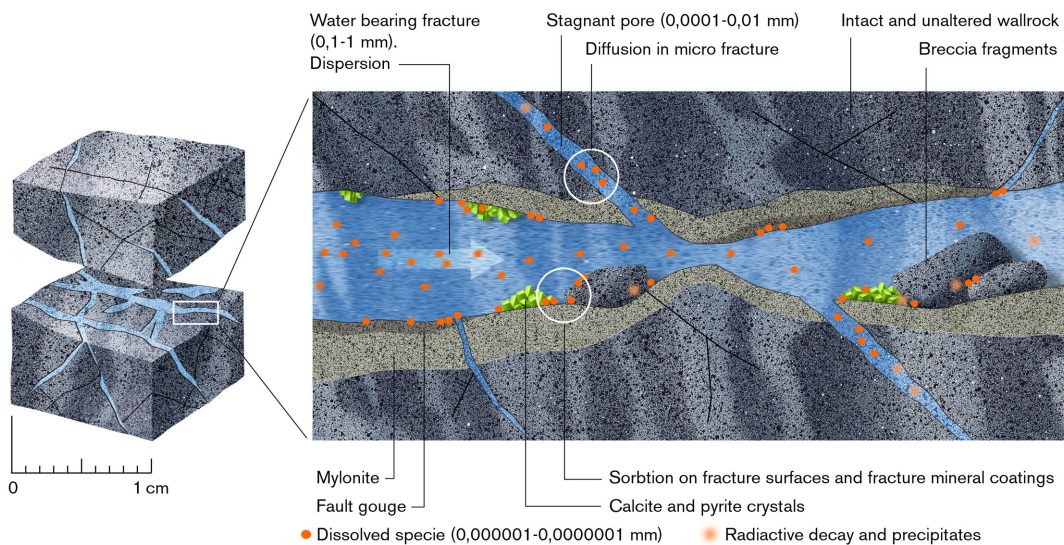
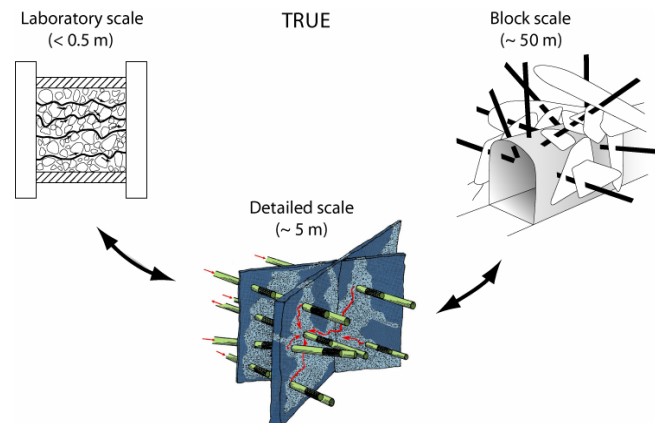

**Figure 4-1** Processes that influence migration of species along a natural rock fracture.



## 4.1 Tracer Retention Understanding Experiments

---



Tracer tests with non-sorbing and sorbing tracers are carried out in the True family of projects. These are conducted at different scales; laboratory scale (< 0.5 m), detailed scale (<10 m) and block scale (up to 100 m) with the aim to improve understanding of transport and retention in fractured rock. The work includes building of hydrostructural models and conceptual microstructure models. Numerical models are used to assess the relative contribution of flow-field related effects and acting processes (diffusion and sorption) on *in situ* retention.

The first *in situ* experiment (True-1) performed in the detailed scale and the True Block Scale series of experiments have come to their respective conclusion and the evaluation and final reporting are completed. Complementary field work and modelling are currently performed as part of two separate but closely coordinated continuation projects.

The True Block Scale Continuation project aims at obtaining additional understanding of the True Block Scale site.

The True-1 Continuation project is a continuation of the True-1 experiment. According to present plans the True-1 site will be injected with resin and excavated and analysed. The objectives are to obtain insight in the internal structure of the investigated feature and to study fixation of sorbing radioactive tracers.

Prior to the resin injection in Feature A complementary hydraulic and tracer tests are performed to better understand Feature A and its relation to the surrounding fracture network. In addition, a dress rehearsal of *in situ* resin injection is realised through a characterisation project focused on fault rock zones. Furthermore, attempts are made to assess fracture apertures using radon concentrations in groundwater.

---

### 4.1.1 True Block Scale Continuation

The objective of True Block Scale Continuation (BS2) is to improve the understanding of transport pathways at the block scale, including assessment of effects of geometry, macrostructure, and microstructure, and the ability to predict retention using geological information. The project is focussed on the existing True Block Scale site and it comprises two separate phases:

- BS2a Continuation of the True Block Scale (Phase C). Pumping and sampling until the end of 2002 including employment of developed enrichment techniques to lower detection limits. Complementary modelling work to support the BS2b *in situ* tracer tests.
- BS2b *In situ* tracer tests based on the outcome of the BS2a analysis. *In situ* tests are preceded by reassessment of the need to optimise/remediate the piezometer array. The specific objectives of BS2b are to be formulated on the basis of the outcome of BS2a.

## **Achievements**

The main work in progress is on BS2b. Reporting of three cross hole interference tests (CPT-1 through CPT-3) aimed at identifying suitable sink and injection sections for the planned injection tests is in progress

Long term tests with non-sorbing tracers (CPT-4a and CPT-4b) have shown that two flow paths can be used for BS2b radioactive sorbing tests – injections in KI0025F02:R3 (Structure #19) and KI0025F02:R2 (background fracture BG1, formerly denoted Structure #25) with pumping in KI0025F03:R3 (Structure #19). The *in situ* test with radioactive sorbing tracers has been carried out and the official part of the test is now terminated.

Modelling work, as preparation for model predictions of the BS2b radioactive sorbing tests, somewhat hampered by difficulties to assign correct outer boundary conditions. A decision was taken to use a model size of 500 m cube. The model predictions (four modelling teams) of sorbing tests were started late September. The results of the prediction will be duly filed beforehand and subsequently compared with *in situ* results at a technical committee meeting planned for in November.

### **4.1.2 True-1 Continuation**

The True-1 Continuation project is a continuation of the True-1 experiments, and the experimental focus is mainly on the True-1 site, although work is also made at other locations at Äspö HRL. The main components of the test are: complementary *in situ* tests /Andersson *et al.*, 2002a/, radon investigations /Byegård *et al.*, 2002/, fault rock zone characterisation studies (including epoxy resin injection), and investigations in the laboratory of the sorption characteristics of rim zone and fault gouge material.

## **Achievements**

The major work performed during this quarter is within the fault rock zones characterisation studies. Joint visual inspection of overcored 277 mm cores indicated a wealth of information ranging from the overall pattern of connected pore space on a metre scale down to highly variable types and shapes of pores down to microscopic scale.

An optimised sectioning plan for the available material has been set up and followed. A local quarry sawed the 277 mm cores according to the plan. Before sectioning professional photo documentation of the complete cores were performed. Half-pipe of the sectioned cores are retained at Äspö HRL whereas the remainder of the collected core material has been delivered to Itasca Geomekanik for detailed analyses and continued sectioning. A report has been produced which accounts for the overcoring work /Hansen and Staub, 2004/ and documents the overcored structures in detailed maps and photo images. An activity plan for analyses of pore space has been prepared which details the strategy for image analyses of the exposed surfaces.

Preliminary results from the ongoing laboratory experiments on sorption characteristics of rim zone and fault gouge materials are available and the program is progressing according to plan. A good correspondence is noted between previously estimated  $K_d$ -values /Andersson *et al.*, 2002b/ and the new measured data.

## 4.2 Long Term Diffusion Experiment

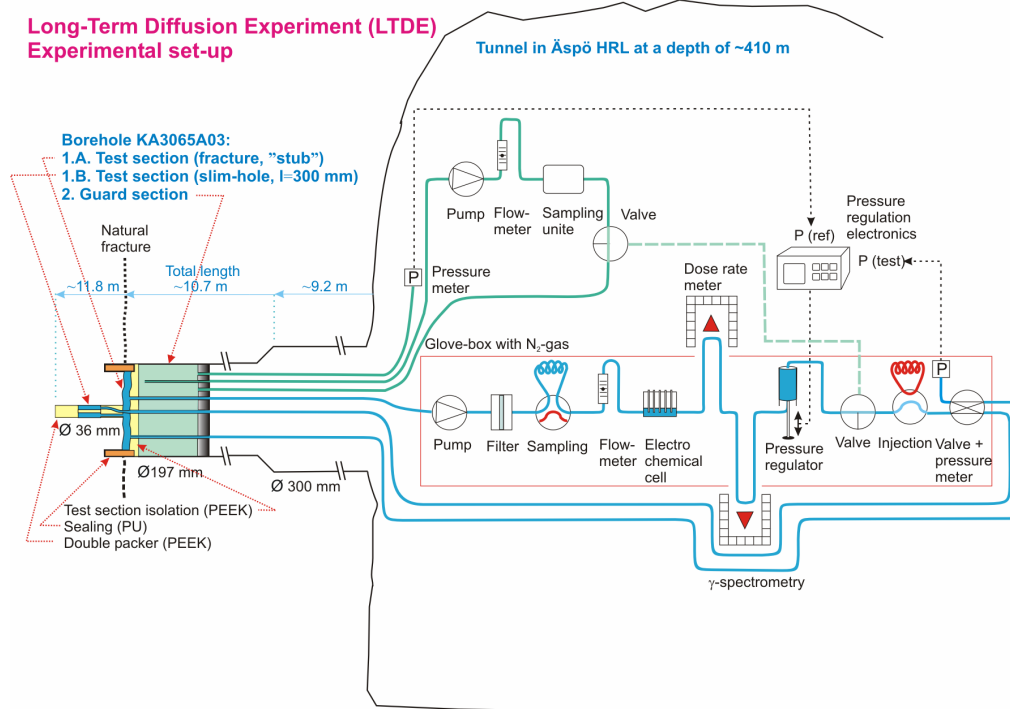

This experiment is performed to investigate diffusion and sorption of solutes in the vicinity of a natural fracture into the matrix rock and directly from a borehole into the matrix rock.

The aims are to improve the understanding of diffusion and sorption processes and to obtain diffusion and sorption data at *in situ* conditions.

A core stub with a natural fracture surface is isolated in the bottom of a large diameter telescoped borehole and a small-diameter borehole is drilled through the core stub and beyond into the intact unaltered bedrock. Tracers will be circulated over a period of three to four years after which the borehole is overcored and analysed for tracer content.

### Achievements

Accomplished activities during this quarter have been on installations, installation tests and documentation. The objectives of this work are to install all equipments and systems at the experimental site before start of the experiment and to test the systems at various conditions at the site. The accomplished activities comprise further installations in the experimental container and installation of an LTDE computer and web camera as part of the new data network (Äspö.net). In addition, activities to solve problems with the electronics that control the pressure regulation in the test section are going on and alternatives to the present equipment are explored.

Pre-tests are in progress with the main objectives to investigate the natural water flow rates and gradients in the vicinity of LTDE as well as the possible hydraulic interferences and their magnitudes in Äspö HRL. Possible counter-actions in case of experimental failure are also tested. The experimental parts of pre-tests 1 through 6 are finished and evaluation of experimental data is in progress.

A collaborative effort for supporting laboratory experiments has been planned together with AECL, within the framework of the collaboration between SKB and OPG. Final

preparations for the out take of core samples from borehole KA3065A03 have been done. The samples will be used for supporting laboratory experiments at AECL.

A report that details the results of previous work on the LTDE site characterisation and development of a descriptive models at different scales has been printed /Winberg *et al.*, 2003/.

### 4.3 Radionuclide Retention Experiments

---

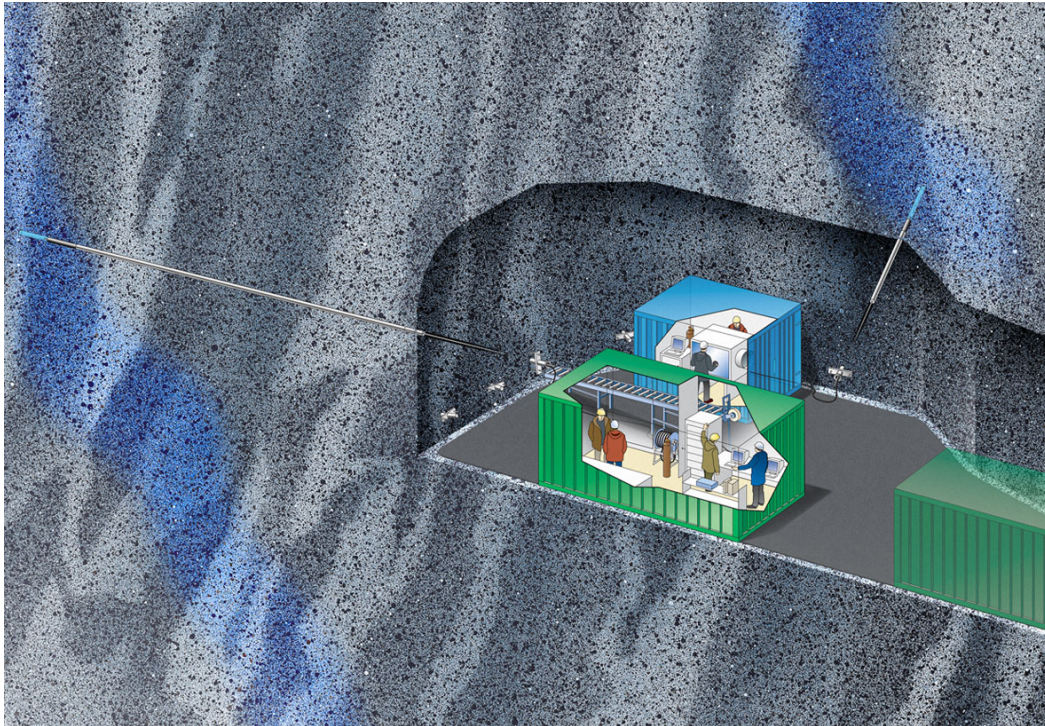

Radionuclide Retention Experiments are carried out with the aim to confirm results of laboratory studies *in situ*, where natural conditions prevail concerning e.g. redox conditions, contents of colloids, organic matter, and bacteria in the groundwater.

The experiments are carried out in special borehole laboratories, Chemlab 1 and Chemlab 2, designed for different kinds of *in situ* experiments.

The laboratories are installed in boreholes and experiments can be carried out on bentonite samples and on tiny rock fractures in drill cores at *in situ* conditions. The present focus is on:

- Radiolysis experiments in Chemlab 1, influence of radiolysis products on the migration of the redox-sensitive element technetium in bentonite.
- Migration of actinides in Chemlab 2, experiments with actinides in a rock fracture.

---

#### **Achievements – Radiolysis experiments**

In the end of 2002, two kinds of radiolysis experiments were performed. In the indirect radiolysis experiments the groundwater is irradiated before it comes in contact with the experiment cell containing bentonite and reduced technetium. Radicals produced from water radiolysis will not reach the experiment cell, but the molecular products ( $H_2O_2$ ,  $O_2$ , and  $H_2$ ) will influence the redox chemistry in the cell. In the other type, direct radiolysis experiments, the irradiation source is placed in the experiment cell, close to the reduced technetium, and thereby the radicals produced may play a role.

The experiments have been analysed and the major conclusions are that technetium was to some extent oxidised in the direct radiolysis experiment and had started to diffuse whereas in the indirect radiolysis experiment technetium was only found at its original position and had probably not been oxidised. The evaluation of data is finished and the final report is being reviewed. No additional experiments are presently in progress or planned.

### **Achievements – Migration of actinides**

In these experiments a cocktail containing actinides is added to groundwater before pumping it through a longitudinal natural fracture in a drill core placed in Chemlab 2. The laboratory reservoir containing the tracer cocktail (uranium and technetium) was prepared by FZK/INE.

The last *in situ* experiment (in borehole KJ0044F01) has been initiated and the radionuclide injection was performed in May 2004 and ground water is being pumped through the core.

Samples of the breakthrough solution have been sent to FZK/INE for analysis. The samples revealed that uranium seems to be desorbed, see Figure 4-2. Samples are regularly sent to FZK/INE for analysis in order to see when the desorption phase is finished so that the experiment can be terminated.

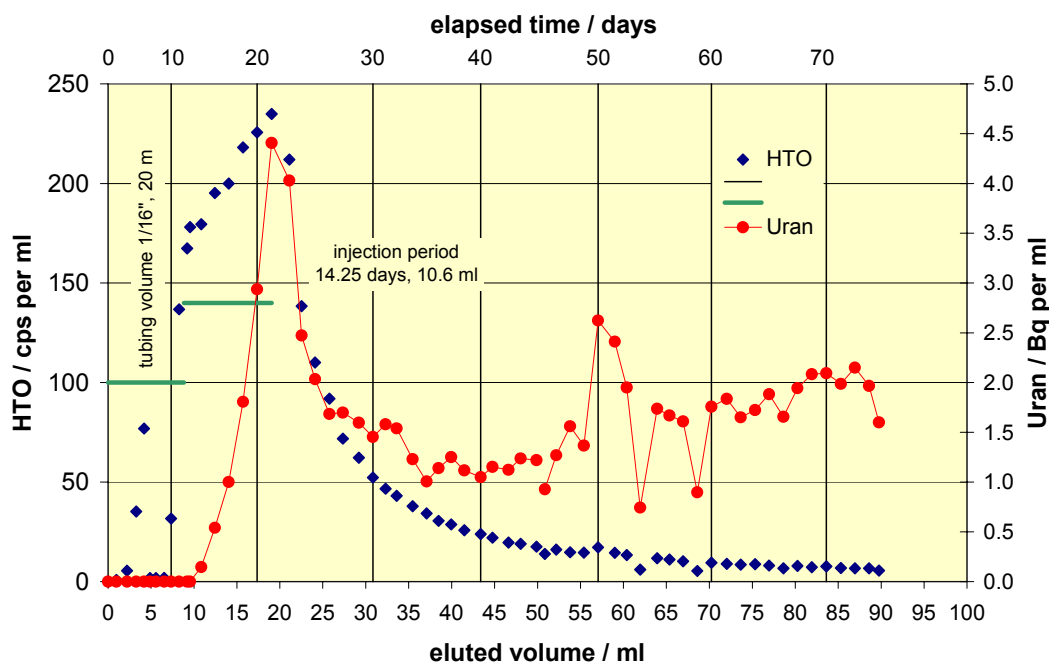

**Figure 4-2** Breakthrough curves of inert tracer (HTO) and uranium. Note the increase in uranium concentration during the last 50 days.

## 4.4 Colloid Project

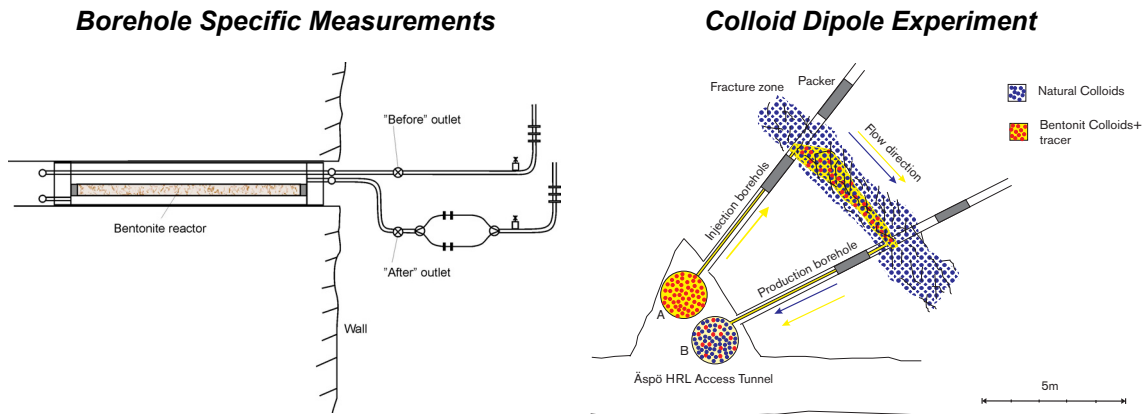

In the Colloid Project the concentration, stability, and mobility of colloids in the Äspö environment are studied. The project comprises studies of the potential of colloids to enhance solute transport and the potential of bentonite clay as a source for colloid generation. The Colloid Project includes laboratory experiments, background measurements, borehole specific measurements, and colloid dipole experiments.

### Achievements

The borehole specific measurements that were initiated in January 2003, when six "colloid reactors" were installed in four boreholes in Äspö HRL and in two boreholes at Olkiluoto, have all been finalised. The status report is delayed due to delay in reporting from Posiva. SKB decided to wait for these results since they are crucial for the inter comparison of the results from the tests performed at Äspö and Olkiluoto. The Posiva results are now available and a draft of the status report is planned to be available at the end of November. The compilation of the final report including laboratory experiments, background measurements and borehole specific measurements is foreseen to be ready in March 2005.

The preparations for the Colloid Dipole experiment that will be carried out in co-operation between SKB, INE and Posiva are in progress. Several planning meetings have been held and a preliminary project plan and the material for project decision have been prepared.

Preparation and stability experiments of colloids to be used in the experiment will be started in October and the outcome of the laboratory study will be presented in a report. Based on results from tests with conservative tracers, Feature B at the True-1 site seems to be a suitable location for the experiments. The final decision of the location will be taken after discussion with the team working in the True project.

A measuring campaign of natural colloids in the groundwater will start in the turn of the month October/November depending on other activities in the tunnel. *In situ* measurements of colloids (LIBD-measurements) are planned in following boreholes: HA2780A, KKTT3:R3, KXTT4:R4, and KA1755A. Water sampling is planned at the following measuring points: KR0012B, SA1229A, HA1330B, KA1755A, SA2074A, SA2273A, KA3110A and KXTT3:R3, KXTT4:R4. Electric conductivity, pH, Eh, and O<sub>2</sub>-content in the water will be analysed.

## 4.5 Microbe Project



The Microbe Project has been initiated in the Äspö HRL for studies of the microbial activity in groundwater at *in situ* conditions. The major objectives are:

- To offer proper circumstances for research on the effect of microbial activity on the long- term chemical stability of the repository environment.
- To provide *in situ* conditions for the study of bio-mobilisation of radionuclides.
- To present a range of conditions relevant for the study of bio-immobilisation of radionuclides.
- To enable investigations of bio-corrosion of copper under conditions relevant for a high level radioactive waste repository.

The main Microbe site is on the 450-m level where a laboratory container has been installed with laboratory benches, an anaerobic gas box and an advanced climate control system. Three core drilled holes, KJ0050F01, KJ0052F01 and KJ0052F03, intersecting water conducting fractures are connected to the Microbe laboratory via tubings. Each borehole has been equipped with a circulation system offering a total of 2000 cm<sup>2</sup> of test surface.

Retention of naturally occurring trace elements in the groundwater by Biological Iron Oxides is investigated at a site at tunnel length 2200A m. There is a vault with a borehole that delivers groundwater rich in ferrous iron and iron oxidising bacteria. The borehole is connected to two 200 x 30 x 20 cm artificial channels that mimic ditches in the tunnel. The channels have rock and artificial plastic support that stimulate Biological Iron Oxide formation.

At 907A m tunnel length, a small vault supports a ditch with groundwater that is rich in ferrous oxides and iron oxidising bacteria. This ditch is used as a natural analogue to the artificial channels at 2200A m. This site was destroyed by a flooding event fall 2003 and will not be used during 2004.

A unique ecosystem of sulphur oxidising bacteria exists at tunnel length 1127B m, in the sulphur pond. Apart from being an intriguing site from a microbiological perspective, it offered possibility to investigate microbial effects on the sulphur cycle in underground environments. However, changes in groundwater flows during 2003 has dried out the site and it can not be used in the Microbe experiments.

## ***Achievements***

The main site is the Microbe laboratory at the -450 m level. In addition, three more sites, two along the A-side of the tunnel at 907 and 2200 m tunnel length and one at the B-side of the tunnel at 1127 m, were established during 2002. However, a devastating flood event occurred summer 2003 at the 907-site, and filled it with sand. This site will, therefore, not be used during 2004.

In the Microbe laboratory, new biofilm experiments with mineral and glass surfaces have been loaded and started during mid February using the KJ0052F03 circulation. Immobilisation of radionuclides on the biofilms will be investigated at Nuclear Chemistry, Chalmers.

New biomass determination equipment has been successfully tested and introduced in the Microbe laboratory. It is based on the measurement of ATP (an energy transport molecule that is present in all cells). A manuscript is presently being compiled.

Experiments on the succession of biological iron oxides at the 2200 m Microbe site started in June. Sampling was run daily for two weeks thereafter for another six weeks at two intervals. The field work was finished in mid August and analyses are ongoing in the laboratories at Gothenburg and Toronto Universities.

The gas chromatograph (Kappa-V) in the Microbe laboratory level needed service in September since there was a clogging problem. Two valve heads had to be replaced which was done during week 40. In addition a new cryo-trap was installed on the injection loop 2 in September.



## 4.6 Matrix Fluid Chemistry

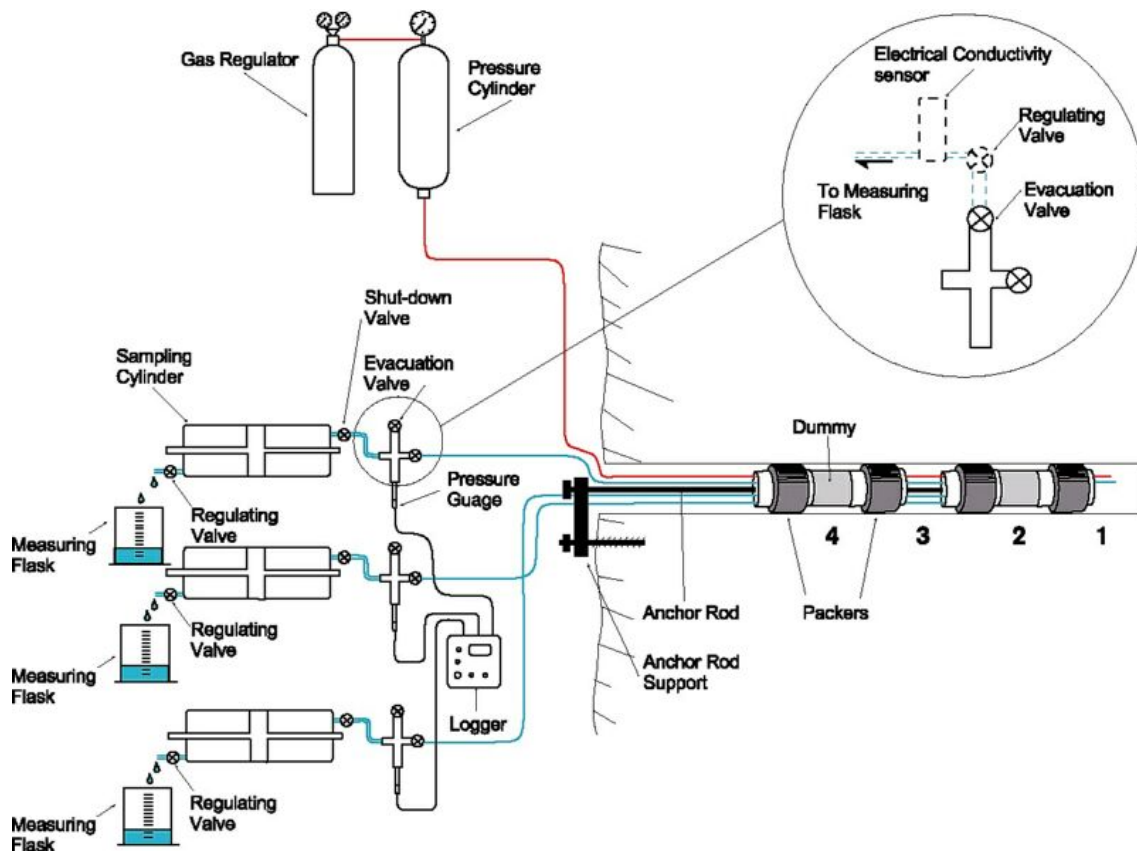

The main objectives of the Matrix Fluid Chemistry experiment are to understand the origin and age of fluids/groundwaters in the rock matrix pore space and in micro-fractures, and their possible influence on the chemistry of the groundwaters from the more highly permeable bedrock.

Matrix fluids are sampled from a borehole drilled into the rock matrix. Fluid inclusions in core samples have also been studied to determine their contribution, if any, to the composition of the matrix fluids/groundwaters.

### **Achievements**

The first phase of the project (Matrix Fluid Chemistry Experiment) is finalised and reported /Smellie *et al.*, 2003/. The major conclusion from this phase is that pore water can successfully be sampled from the rock matrix and there is no major difference in chemistry compared to groundwaters from more highly conductive fracture zones in the near-vicinity. The continuation phase of the project (2004–2006) will focus on areas of uncertainty which remain to be addressed. However, this phase requires an initial feasibility study to assess the potential for further characterising of the matrix borehole.

The continuation phase is proceeding slowly. The feasibility study is focussed on the impact of tunnel construction (Äspö Pillar Stability Experiment) on the hydrogeology and hydrochemistry in the vicinity of the experimental matrix borehole KF0051A01. Porosity measurements on drillcore material to supplement data from the Matrix Fluid Chemistry Experiment have been carried out successfully and reporting is in progress.

The reporting from both these studies has been delayed. It is hoped that the porosity measurements will be reported by the end of November, 2004 and likewise for the impact study.

## 4.7 Task Force on Modelling of Groundwater Flow and Transport of Solutes

---

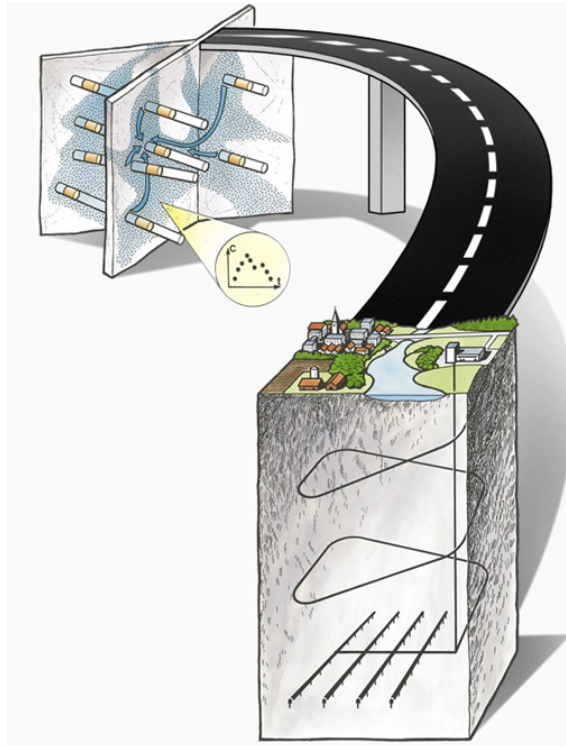

The Äspö Task Force on Modelling of Groundwater Flow and Transport of Solutes is a forum for the organisations supporting the Äspö HRL to interact in the area of conceptual and numerical modelling of groundwater flow and transport of solutes in fractured rock.

The Task Force shall propose, review, evaluate and contribute to the modelling work in the project. In addition, the Task Force shall interact with the principal investigators responsible for carrying out experimental and modelling works for Äspö HRL.

The work within the Äspö Task Force constitutes an important part of the international co-operation within the Äspö Hard Rock Laboratory.

---

### **Achievements**

In the Task Force, work has been in progress mainly in Task 6 – Performance Assessment Modelling Using Site Characterisation Data. Task 6 tries to bridge the gap between Performance Assessment (PA) and Site Characterisation (SC) models by applying both approaches for the same tracer experiment. It is hoped that this will help to identify the relevant conceptualisations (in processes/structures) for long term PA predictions and identify site characterisation data requirements to support PA calculations.

Modelling and review of modelling are proceeding according to the updated plan decided on in the beginning of this year when new modelling tasks were identified that will prolong the project with one year and approximately two additional Task Force meetings. A workshop for the delegates only, was held at Arlanda airport. At the meeting, issues on how to steer and improve the work within the Task Force were discussed. The 19<sup>th</sup> Task Force meeting was held in Naantali in Finland in September. At this meeting e.g. modelling results for Tasks 6E and 6F were presented and discussed. In addition, it was decided to initiate Task 7, which concerns a long-term pumping test.

The status of the specific modelling tasks is given in brackets in Table 4-1.

**Table 4-1 Status of the specific modelling tasks.**

Sub-task	Status
6A	Model and reproduce selected True-1 tests with a PA model and/or a SC model to provide a common reference. (Finalised, reported, and external review in progress).
6B	Model selected PA cases at the True-1 site with new PA relevant (long term/base case) boundary conditions and temporal scales. This task serves as means to understand the differences between the use of SC-type and PA-type models, and the influence of various assumptions made for PA calculations for extrapolation in time. (Finalised, reported, and external review in progress).
6C	Develop semi-synthetic, fractured granite hydrostructural models. Two scales are supported (200 m block scale and 2000 m site-scale). The models are developed based on data from the Prototype Repository, True Block Scale, True-1, and Fracture Characterisation and Classification project (FCC). (Finalised, printed as /Dershowitz <i>et al.</i> , 2003/, and external review in progress).
6D	This sub-task is similar to sub-task 6A, and is using the synthetic structural model in addition to a 50 to 100 m scale True-Block Scale tracer experiment. (In progress).
6E	This sub-task extends the sub-task 6D transport calculations to a reference set of PA time scales and boundary conditions. (In progress).
6F	Task 6F is a sensitivity study, which is proposed to address simple test cases, individual tasks to explore processes, and to test model functionality. (In progress).

## 4.8 Padamot

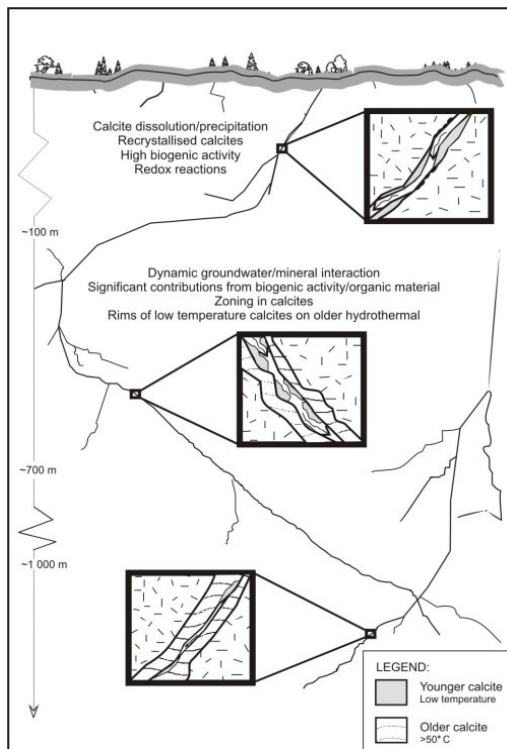

*Potential calcite-groundwater interaction at various depths at Äspö.*

Padamot (Palaeohydrogeological Data Analysis and Model Testing) is an EC-project and will investigate changes in groundwater conditions as a result of changing climate. Because the long term safety of an underground repository depends on the stability of the repository environment, demonstration that climatic impacts attenuate with depth is important. Currently, scenarios for groundwater evolution relating to climate changes are poorly constrained by data and process understanding.

The objectives of Padamot are to:

- Improve understanding and prioritise palaeohydrogeological information for use in safety assessments.
- Collect chemical/isotopic data using advanced analytical methods.
- Construct a database of relevant information and develop numerical models to test hypotheses.
- Integrate and synthesise results to constrain scenarios used in performance assessments.
- Disseminate the results to the scientific community.

The project comprises analytical and modelling tasks. Deep borehole cores from rocks at the Äspö Underground Laboratory and Laxemar (KXL01) are used in the analytical study.

### **Achievements**

The results from Equip, an earlier EC-project, and Padamot have been presented to the project Äspö model 2005. The aim is to include these results in the geological model of the Äspö site.

The final reporting for Work Package 2 – Palaeohydrogeological Characterisation of Sites – is ongoing. The results from the different project groups are found on the Padamot website hosted by British Geological Survey, UK.

The final meeting within the EC- part of the project is planned to take place in Prague in October. However, the SKB part of the project (analytical study of cores from Äspö HRL and Laxemar) will be extended and are planned to continue until 2006. The continuation will include studies of analyses of biomarkers in calcite and the use of laser analyses for Sr and U-series.

## 4.9 Fe-oxides in fractures

---

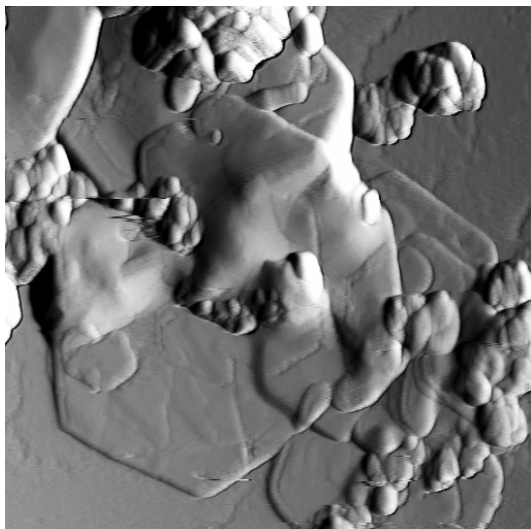

*Atomic Force Microscopy image of green rust sulphate. Image is 2.5 x 2.5 microns*

Proof of reducing conditions at repository depth is fundamental for the safety assessment of radioactive waste disposals. Fe (II) - minerals are common in the bedrock and along fracture pathways and constitute a considerable reducing capacity together with the organic processes. Another area of interest is the radionuclide retention capacity provided by Fe-oxides and -oxyhydroxides in terms of sorption capacity and immobilisation.

The basic idea of the project is to examine Fe-oxide fracture linings, in order to explore for suitable palaeo-indicators for their formation conditions, while at the same time learning about the behaviour of trace component uptake in general, both from the natural material as well as through testing of behaviour in controlled parametric studies in the laboratory.

---

### **Achievements**

The three year project on Fe-oxides started late autumn 2003. A project meeting was held in Copenhagen in August in order to discuss work carried out and plans for the autumn. The present status is that green rust (layered Fe(II,III) hydroxide with a greenish colour, and containing water and anions such as  $\text{CO}_3^{2-}$ ,  $\text{SO}_4^{2-}$  and  $\text{Cl}^-$  in the interlayer) has been successfully identified to character and composition. This job will continue based on natural water samples from Äspö and Bornholm for comparison. Within the study of Fe-oxides in the fracture samples three groups can be identified; Hematite of “old” hydrothermal origin, possible recent precipitates (from the Äspö HRL tunnel and samples artificial Fe-oxides as a product of the drilling. Different methods have been tested for identification of the Fe-oxides and these together with the identification of the Fe-oxides are presented in two manuscripts that will be finalised during this year. The methods include trace element chemistry and Fe isotope studies. New samples of pyrite from the KOV01 borehole (located near SKB’s Canister Laboratory in Oskarshamn) have been provided to the Copenhagen group.

Transformation of green rust to other Fe-compounds at controlled redox conditions that are similar to natural conditions has been studied. The emphasis of this work is on immobilisation of contaminants, including Eu(III). Up to now, the work has focussed on development of the method. The next step will be to study the morphological changes during the formation and transformation of green rust on a substrate of high purity metallic Fe at a variety of potentials to resemble different redox environments in the subsurface.

## 5 Äspö facility

An important part of the Äspö facility is the administration, operation, and maintenance of instruments as well as development of investigation methods. Other issues are to keep the stationary hydro monitoring system (HMS) continuously available and to carry out the programme for monitoring of groundwater head and flow and the programme for monitoring of groundwater chemistry.

### 5.1 Facility operation

---

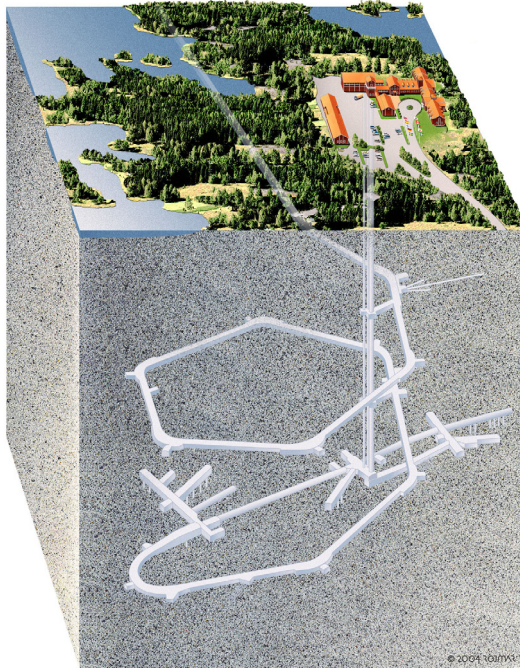

The main goal for the operation of the facility is to provide a safe and environmentally correct facility for everybody working or visiting the Äspö HRL.

This includes preventative and remedy maintenance in order to withhold high availability in all systems as drainage, electrical power, ventilation, alarm and communications in the Hard Rock Laboratory.

---

### **Achievements**

Maintenance and operation of the above and underground facilities are running as well as improvements of the safety and working environment. The availability of the facility systems has continued to be high (above 99%), which means that the goal for 2004 will be fulfilled.

A PC-based maintenance system is being implemented and the aim is that the system will include the planning of maintenance of the facilities, vehicles and machinery.

An automatic registration and object-monitoring system, with the aims of increasing personnel safety underground, was taken into operation for testing in the end of 2003. The system has not functioned as expected and the measurements taken by the supplier have so far not been sufficient. The contract with the supplier has been cancelled, but alternative systems from other suppliers are available.

A steering and control system for soft start of two pumps has been installed and is now in operation. The result of the evaluation of the system was very promising and six

additional pumps are being rebuilt and equipped with similar systems. The final inspection is delayed and is now planned for in November. An overview of the drainage system including dams, pump sumps etc in Äspö HRL is shown in Figure 5-1.

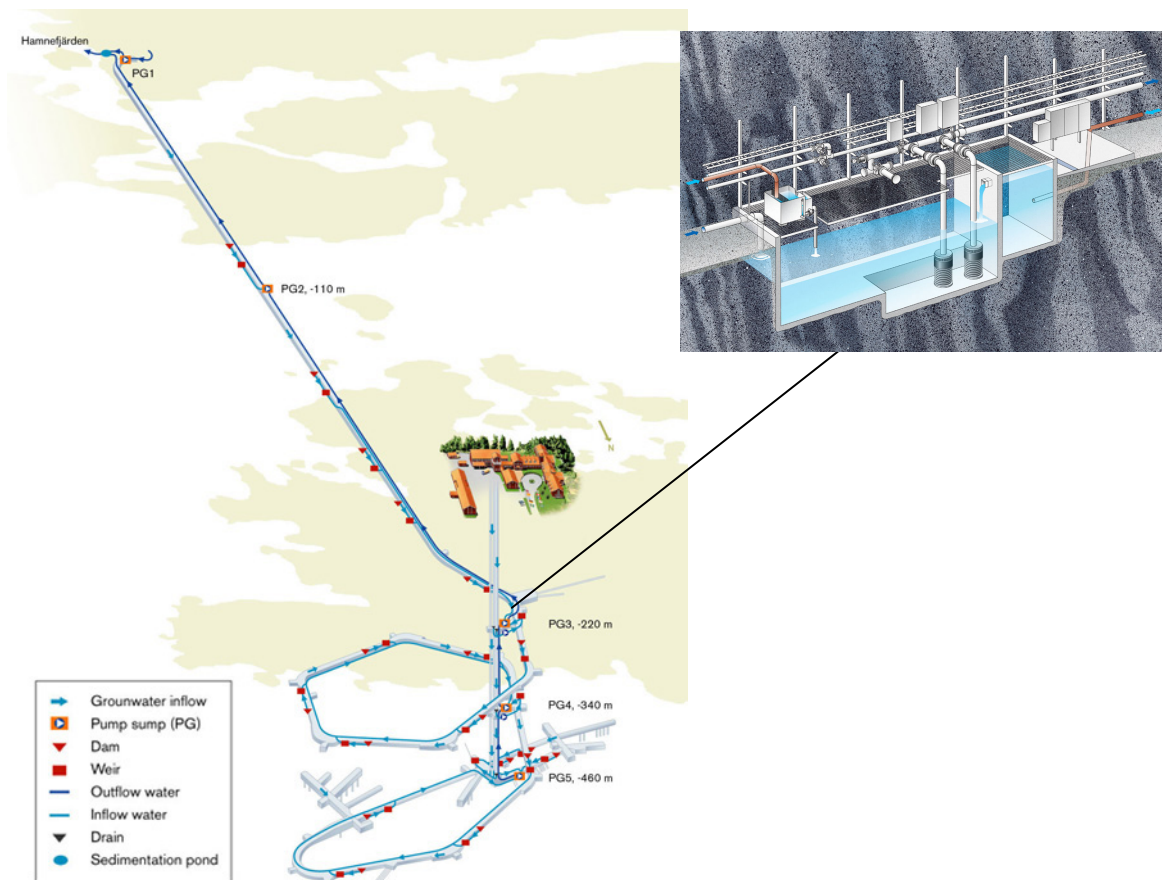
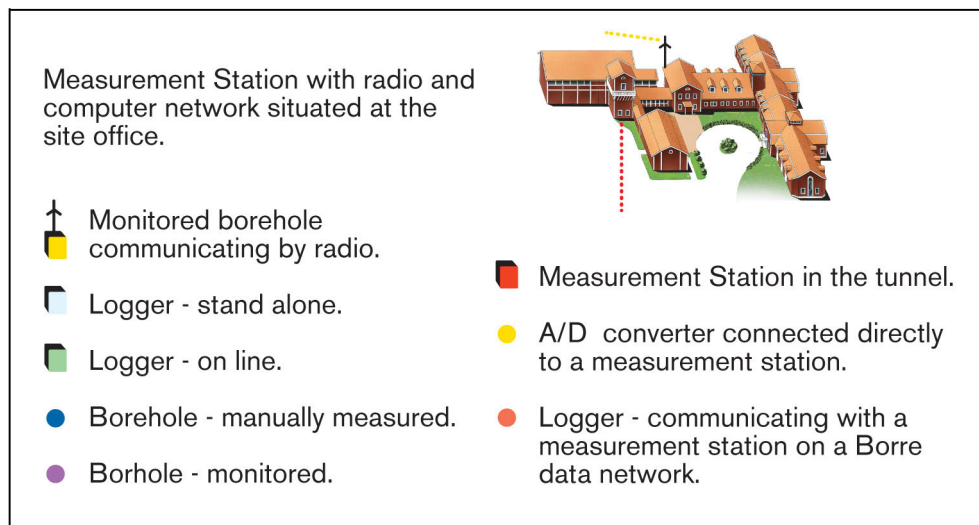
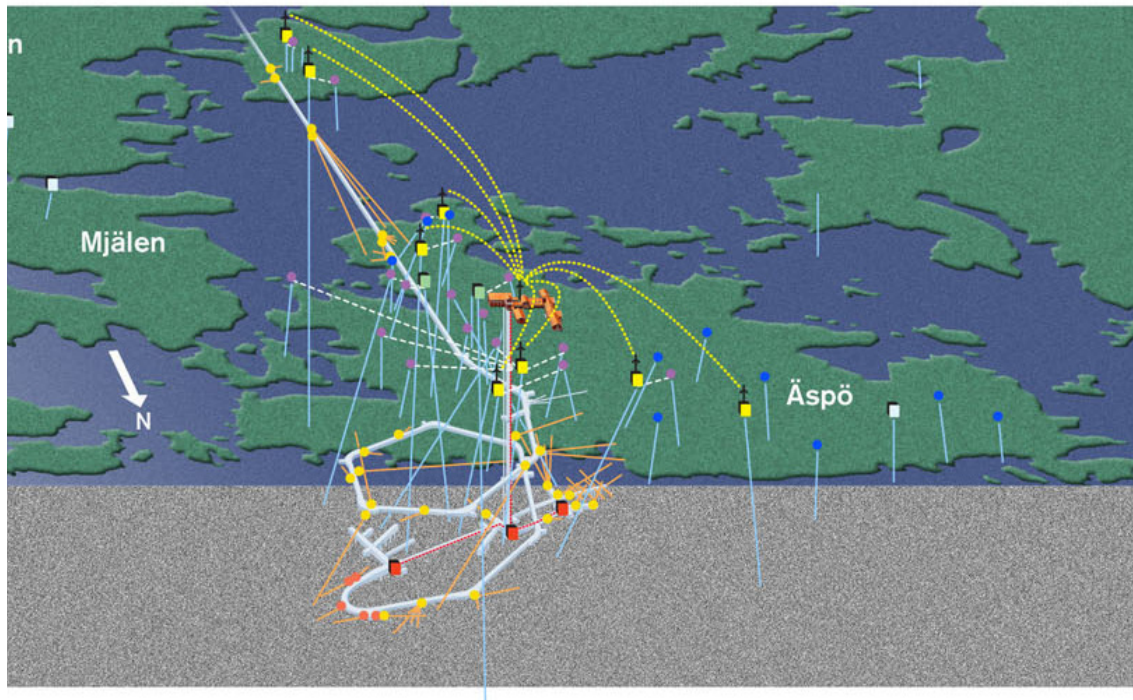

**Figure 5-1** Overview of Äspö HRL drainage system.

The ventilation system for the underground facility has been mapped during the first half of 2004 and a package of measures to increase the air flow in Äspö HRL has been identified. The prognosis shows a potential of a 30% increase in airflow without increase in energy consumption.

A data network (Äspö.net) and a server where all experimental data will be stored are in operation. Data from ten of 17 experiments have been moved there as well as the system for supervision of facilities.

## 5.2 Hydro Monitoring System



The computerised Hydro Monitoring System (HMS), is a network of boreholes and measurement stations where e.g. data of groundwater head, salinity, electrical conductivity, Eh and pH are collected on-line. The data are recorded by more than 400 transducers installed in boreholes on Äspö as well as in boreholes located in the tunnel. All data are transmitted to the main office at Äspö, by radio or modems. Weekly quality controls of preliminary groundwater head data are performed. Absolute calibration of data is performed three to four times per year. This work involves comparison with groundwater levels checked manually in percussion drilled boreholes and in core drilled boreholes. The scope of maintaining such a monitoring network has scientific as well as legal grounds.

### **Achievements**

The system has been performing well. However, improvements are continuously made on the monitoring system to increase the performance of the system.



### 5.3 Programme for monitoring of groundwater head and flow



The monitoring of water levels in surface based boreholes started in 1987. The tunnel excavation started in October 1990 and the first groundwater head (pressure) measurements from tunnel based boreholes were performed in March 1992.

The monitoring is administrated by the computerised hydro monitoring system (HMS), comprising a network of boreholes of which many are equipped with hydraulically inflatable packers, measuring the pressure by means of transducers. Manual levelling is also obtained from the surface boreholes on a regular basis. Water seeping through the tunnel walls is diverted to trenches and further to 21 weirs where the flow is measured.

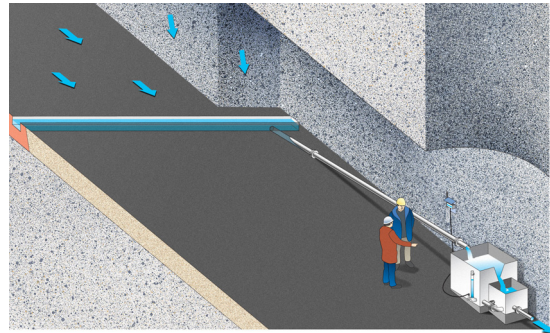

#### **Achievements**

The monitoring points from the previous year have been maintained. The system will continue to support the experiments undertaken and meet the requirements stipulated by the water rights court.

A report summarising the monitoring during 2003 and describing the instrumentation and measurement methods has been published /Nyberg *et al.*, 2004/.

## **5.4 Programme for monitoring of groundwater chemistry**

During the Construction Phase of the Äspö HRL, different types of water samples were collected and analysed with the purpose of monitoring the groundwater chemistry and its evolution as the construction proceeded. At the beginning of the Operational Phase, sampling was replaced by a groundwater chemistry monitoring programme, aiming at a sufficient cover of the hydrogeochemical conditions with respect to time and space within the Äspö HRL. This programme is designed to provide information to determine where, within the rock mass, the hydrogeochemical changes are taking place and at what time stationary conditions are established.

### ***Achievements***

The annual water sampling campaign is in the same way as earlier years scheduled to take place in September – October. The previous sampling campaign took place in September 2003 and the results from the campaign were published in a technical document.

## 6 International co-operation

Seven organisations from six countries participate in the co-operation at Äspö HRL during 2004 besides SKB. OPG (Canada) became a new participant in January 2004 and Nagra (Switzerland) has left the central and active core of participants, but continue in the Matrix Fluid Chemistry project as well as in the Task Force on Modelling of Groundwater Flow and Transport of Solutes.

Most of the participating organisations are interested in groundwater flow, radionuclide transport and rock characterisation. Several organisations are participating in the Äspö Task Force on Modelling of Groundwater Flow and Transport of Solutes, which is a forum for co-operation in the area of conceptual and numerical modelling of groundwater flow and solute transport in fractured rock.

<b>Projects in the Äspö HRL during 2004</b>	<b>Andra</b>	<b>BMWA</b>	<b>Enresa</b>	<b>CRIEPI</b>	<b>JNC</b>	<b>OPG</b>	<b>Posiva</b>
<b>Technology</b>							
Prototype Repository	X	X	X	X	X		X
Backfill and Plug Test			X				
Long Term Test of Buffer Material							X
Cleaning and sealing of investigation boreholes							X
Injection grout for deep repositories							X
KBS-3 method with horizontal emplacement			X			X	X
Large Scale Gas Injection Test	X	X	X		X	X	X
Temperature Buffer Test	X	X	X				
<b>Geo-science</b>							
Äspö Pillar Stability Experiment						X	X
<b>Natural barriers</b>							
Tracer Retention Understanding Experiments	X		X		X		X
Radionuclide Retention Project		X					
Colloid Project		X					X
Microbe Project		X					
Matrix Fluid Chemistry							
Task Force on Modelling of Groundwater Flow and Transport of Solutes	X	X	X	X	X	X	X

### **Participating organisations:**

Agence nationale pour la gestion des déchets radioactifs, Andra, France  
 Bundesministerium für Wirtschaft und Arbeit, BMWA, Germany  
 Empresa Nacional de Residuos Radiactivos, Enresa, Spain  
 Central Research Institute of the Electronic Power Industry, Crieipi, Japan  
 Japan Nuclear Cycle Development Institute, JNC, Japan  
 Ontario Power Generation Inc., Canada  
 Posiva Oy, Finland

## **EC-projects**

SKB takes part in several EC projects of which the representation is channelled through Repository Technology. Three of these projects have been co-ordinated through Repository Technology and are now about to be finalised: Prototype Repository, Cluster Repository Project (Crop) and Net.Excel.

SKB takes also part in work within the IAEA Network of Centres of Excellence.

---

**Febex II** – Full-scale engineered barriers experiment in crystalline host rock phase II  
(1999-07-01 – 2004-10-31 after prolongation with 10 months)

Co-ordinator: Empresa Nacional de Residuos Radiactivos, Spain

Participating countries: Belgium, Czech Republic, Finland, France, Germany, Spain, Sweden, and Switzerland

**Safeti** – Seismic validation of 3-D thermo-mechanical models for the prediction of the rock damage around radioactive spent fuel waste (2001-09-01 – 2004-09-01)

Co-ordinator: The University of Liverpool (Dep of Earth Sciences), United Kingdom

Participating countries: France, Sweden and United Kingdom

**Padamot** – Paleohydrogeological data analysis and model testing (2001-12-01 – 2004-11-30)

Co-ordinator: Nirex Ltd, United Kingdom

Participating countries: Czech Republic, Spain, Sweden and United Kingdom

---

## 7 Environmental research

### 7.1 Äspö Research School

Kalmar University's Research School in Environmental Science at Äspö HRL, called Äspö Research School, started in October, 2002. This School is the result of an agreement between SKB and Kalmar University. It combines two important regional resources, i.e. Äspö HRL and Kalmar University's Environmental Science Section. The activity within the School will lead to: (a) development of new scientific knowledge, (b) increase of geo and environmental scientific competence in the region and (c) utilisation of the Äspö HRL for environmental research. Currently the scientific team consists of a professor of Environmental geology (Dr. Mats Åström), three assistant supervisors and six Ph.D. students. The research activity focuses on biogeochemical systems, in particular in the identification and quantification of dispersion and transport mechanisms of contaminants (mainly metals) in and between soils, sediments, water, biota and upper crystalline bedrock. In addition to financial support from SKB and University of Kalmar, the School receives funding from the city of Oskarshamn.

#### ***Achievements***

There are currently a variety of research activities at sites outside Äspö HRL. These activities have resulted in several scientific publications, and the first Ph.D. dissertation will take place in 2005. In the Äspö HRL, however, the activities are as yet minor. A Ph.D. project focusing on hydrogeology is currently being planned (to be initiated in early 2005), sampling of ground waters together with professor Karsten Pedersen's group took place in spring (results as yet to be interpreted), and a strategy for interpreting existing hydrochemical data on transition metals have been made.

## 8 Documentation

During the period July – September 2004, the following reports have been published and distributed.

### 8.1 Äspö International Progress Reports

**Scherneck H-G, 2001.** Using borehole tides to determine fracture parameters. 1 – Theory, pre-study, and literature survey. IPR-04-08, Svensk Kärnbränslehantering AB

**Scherneck H-G, 2003.** Using borehole tides to determine fracture parameters. 2 – Data analysis. IPR-04-09, Svensk Kärnbränslehantering AB

**Johannesson L-E, Gunnarsson D, Sandén T, Börgesson L, 2004.** Prototype Repository. Installation of buffer, canisters, backfill, plug and instruments in Section II. D15 and D17. IPR-04-13. IPR-04-13, Svensk Kärnbränslehantering AB

**Goudarzi R, Börgesson L, Sandén T, Barcena I, 2004.** Temperature Buffer Test. Sensors data report (Period: 030326-040101) Report No:2. IPR-04-14, Svensk Kärnbränslehantering AB

**Forsmark T, Forsman I, Rhén I, 2004.** Prototype Repository. Hydraulic tests and deformation measurements during operation phase, test campaign 1, interference test. IPR-04-16, Svensk Kärnbränslehantering AB

**Pusch R, Svemar C, 2004.** EBS Task Force. Proceedings from Task Force-related meeting on Buffer and Backfill modelling. IPR-04-23, Svensk Kärnbränslehantering AB

**Goudarzi R, Johannesson L-E, 2004.** Prototype Repository. Sensors data report (Period: 010917-040301). Report No:9. IPR-04-24, Svensk Kärnbränslehantering AB

**Goudarzi R, Johannesson L-E, 2004.** Prototype Repository. Sensors data report (Period: 010917-040601). Report No:10. IPR-04-36, Svensk Kärnbränslehantering AB

**Pedersen K, Kennedy C, Nederfeldt K-G, Bergelin A, 2004.** Prototype Repository. Chemical measurements in buffer and backfill; sampling and analyses of gases. IPR-04-26, Svensk Kärnbränslehantering AB

**Goudarzi R, Börgesson L, Röshoff K, Edelman M, 2004.** Canister Retrieval Test. Sensors data report (Period 001026-040501) Report No:8. IPR-04-28, Svensk Kärnbränslehantering AB

**Cheng H, Cvetkovic V, 2003.** Äspö Task Force. Tasks 6A, 6B and 6B2. Modelling of sorbing tracer breakthrough for Tasks 6A, 6B and 6B2. IPR-04-30, Svensk Kärnbränslehantering AB

**Crawford J, Moreno L, 2003.** Äspö Task Force. Task 6A and 6B/6B2. Modelling of the STT1b, detailed scale tracer tests at Äspö using the channel network model. IPR-04-31, Svensk Kärnbränslehantering AB

**Dershowitz W, Uchida M, Shuttle D, 2003.** Äspö Task Force. Task 6A, 6B and 6B2. GoldSim and FracMan/LTG Modelling. Performance assessment modelling using site characterisation data (PASC). IPR-04-32, Svensk Kärnbränslehantering AB

**Doughty C, Uchida M, 2003.** Äspö Task Force. PA calculations for feature A with third-dimension structure based on tracer test calibration. IPR-04-33, Svensk Kärnbränslehantering AB

## **8.2 Technical Documents and International Technical Documents**

No Technical or International Technical Documents have been published during the third quarter 2004.

## 9 References

**Andersson P, Wass E, Gröhn S, Holmqvist M, 2002a.** True-1 Continuation Project. Complementary investigations at the True-1 site – Crosshole interference, dilution and tracer tests, CX-1 - CX-5.

IPR-02-47. Svensk Kärnbränslehantering AB

**Andersson P, Byegård J, Dershowitz B, Doe T, Hermanson J, Meier P, Tullborg E-L, Winberg A, 2002b.** Final report of the TRUE Block Scale projekt 1.

Characterisation and model development.

TR-02-13, Svensk Kärnbränslehantering AB

**Byegård J, Ramebäck H, Widestrand H, 2002.** True-1 Continuation Project. Use of radon concentrations for estimation of fracture apertures – Part 1: Some method developments, preliminary measurements and laboratory experiments.

IPR-02-68. Svensk Kärnbränslehantering AB

**Dershowitz W, Winberg A, Hermansson J, Byegård J, Tullborg E-L, Andersson P, Mazurek M, 2003.** Äspö Hard Rock Laboratory. Äspö Task Force on modelling of groundwater flow and transport of solutes. Task 6c. A semi-synthetic model of block scale conductive structures at the Äspö HRL.

IPR-03-13. Svensk Kärnbränslehantering AB

**Goudarzi R, Johannesson L-E, 2004.** Prototype Repository. Sensors data report (Period: 010917-040601). Report No:10.

IPR-04-36, Svensk Kärnbränslehantering AB

**Goudarzi R, Börgesson L, Röshoff K, Edelman M, 2004a.** Canister Retrieval Test. Sensors data report (Period: 001026-040501). Report No: 8.

IPR-04-28. Svensk Kärnbränslehantering AB

**Goudarzi R, Gunnarsson D, Johannesson L-E, Börgesson L, 2004b.** Backfill and Plug test. Sensors data report (Period: 990601-040101) Report No: 8.

IPR-04-43. Svensk Kärnbränslehantering AB

**Goudarzi R, Börgesson L, Sandén T, Barcen, I, 2004c.** Temperature Buffer Test. Sensors data report (Period: 030326-040401) Report No:3.

IPR-04-29. Svensk Kärnbränslehantering AB

**Hansen L M, Staub I, 2004.** TRUE-1 Continuation project. Fault rock zones characterisation. Overcoring (300mm) of impregnated fault rock zones at chainages 2/430, 2/545, 2/163 and 1/600m.

IPR-04-10. Svensk Kärnbränslehantering AB

**Magnor B, 2004.** Äspö Pillar Stability Experiment. Geological mapping of tunnel TASQ.

IPR-04-03. Svensk Kärnbränslehantering AB



**Nyberg G, Jönsson S, Wass E, 2004.** Äspö hard rock laboratory. Hydro monitoring program. Report for 2003.

IPR-04-46. Svensk Kärnbränslehantering AB

**SKB, 2001.** RD&D-Programme 2001. Programme for research, development and demonstration of methods for the management and disposal of nuclear waste.

TR-01-30. Svensk Kärnbränslehantering AB

**SKB, 2004.** Äspö Hard Rock Laboratory. Planning Report for 2004.

IPR-04-12. Svensk Kärnbränslehantering AB

**Smellie J, Waberg N, Frape S, 2003.** Matrix fluid chemistry experiment. Final report. June 1998-March 2003.

TR-03-18. Svensk Kärnbränslehantering AB

**Sundberg J, 2002.** Determination of thermal properties at Äspö HRL. Comparison and evaluation of methods and methodologies for borehole KA 2599 G01.

R-02-27. Svensk Kärnbränslehantering AB

**Sundberg J, 2003a.** Thermal properties at Äspö HRL. Analysis of distribution and scale factors.

R-03-17. Svensk Kärnbränslehantering AB

**Sundberg J, 2003b.** A strategy for the model development during site investigations version 1.0.

R-03-10. Svensk Kärnbränslehantering AB

**Sundberg J, Hälldahl L, Kukkonen I, 2003.** Comparison of thermal properties measured by different methods.

R-03-18. Svensk Kärnbränslehantering AB

**Winberg A, Hermansson J, Tullborg E-L, Staub I, 2003.** Long-Term Diffusion Experiment. Structural model of the LTDE site and detailed description of the characteristics of the experimental volume including target structure and intact rock section.

IPR-03-51. Svensk Kärnbränslehantering AB