

Technical Report

TR-10-18

**Design, construction and initial state
of the underground openings**

Svensk Kärnbränslehantering AB

December 2010

Svensk Kärnbränslehantering AB

Swedish Nuclear Fuel
and Waste Management Co

Box 250, SE-101 24 Stockholm
Phone +46 8 459 84 00



ISSN 1404-0344

SKB TR-10-18

ID 1177188

Updated 2013-01

Design, construction and initial state of the underground openings

Svensk Kärnbränslehantering AB

December 2010

Keywords: Underground openings, Safety report, Design premise, Observational method, Site adaptation, Verification, Reference design, Reference methods, Initial state.

A pdf version of this document can be downloaded from www.skb.se.

Update notice

The original report, dated December 2010, was found to contain editorial errors which have been corrected in this updated version.

Preface

An important part of SKB's licence application for the construction, possession and operation of the KBS-3 repository is the safety report. The safety report addresses both safety during operation of the KBS-3 repository facility (**SR-Operation**), and the long-term safety of the KBS-3 repository (**SR-Site**).

For the construction of the KBS-3 repository SKB has defined a set of production lines:

- the spent nuclear fuel,
- the canister,
- the buffer,
- the backfill,
- the closure,
- the underground openings.

These production lines are reported in separate *Production reports*, and in addition there is a *Repository production report* presenting the common basis for the reports.

This set of reports addresses design premises, reference design, conformity of the reference design to design premises, production and the initial state, i.e. the results of the production. Thus the reports provide input to **SR-Site** concerning the characteristics of the as built KBS-3 repository and to **SR-Operation** concerning the handling of the engineered barriers and construction of underground openings.

The preparation of the set of reports has been lead and coordinated by Lena Morén with support from Karin Pers, Marie Wiborgh and Roland Johansson.

This report has been authored by Mats Holmberg.

Summary

The report is included in a set of *Production reports*, presenting how the KBS-3 repository is designed, produced and inspected. The set of reports is included in the safety report for the KBS-3 repository and repository facility.

The report provides input on the *initial state* of the underground openings for the assessment of the long-term safety, SR-Site. The initial state refers to the properties of the underground openings at final disposal, backfilling or closure. In addition, the report provides input to the operational safety report, SR-Operation, on how the underground openings shall be constructed and inspected.

The report presents the design premises and the methodology applied to design the underground openings and adapt them to the site conditions so that they conform to the design premises. It presents the reference design at Forsmark and its conformity to the design premises. It also describes the reference methods to be applied to construct and inspect the different kinds of underground openings. Finally, the initial state of the underground openings and its conformity to the design premises is presented.

Design premises for the underground openings

The design premises for the underground openings are based on regulations; the functions of the KBS-3 repository; the design basis cases from the assessment of the long-term safety; the design basis events from the assessment of the operational safety; technical feasibility and the planned construction.

The underground openings shall accommodate the sub-surface part of the KBS-3 repository facility. The underground openings as such do not contribute to the safety of the KBS-3 repository and do not have any barrier functions. However, the locations of the deposition holes with respect to the thermal, hydrological and mechanical properties of the rock are important for the utilisation of the rock as a barrier and thus for the safety of the repository. Furthermore, irreversible changes in the rock surrounding the rock excavation, i.e. the excavation damaged zone (EDZ), and engineered and residual materials that remain in the rock may impact the barrier functions of the rock and/or the engineered barriers. Design premises for the acceptable placement of deposition areas and deposition holes as well as restrictions on engineered and residual materials are provided from the assessment of the long-term safety. The underground openings shall also be designed to conform to design premises from the engineered barriers and plugs, and to design premises related to the development and operation of the repository facility.

Rock engineering

The objectives of rock engineering are to ensure that the site-adapted layout as well as the construction and as-built underground openings, conform to the design premises. SKB will apply the so called *Observational Method* for adapting the layout of the repository and construction of the underground openings to the successively developed description of the site. The design will always be based on the most recent site descriptive model and consider the most likely ground conditions as well as possible deviations ranging from most favourable to worst conceivable conditions. Application of the Observational Method implies that hazards that contribute to the risk for nonconformity to the design premises are identified, that models predicting the hazard and calculating parameters that will subsequently be observed during construction are established, and that action plans for handling of possible adverse conditions are defined. At designated milestones formal comparisons of the design assumptions and the encountered ground conditions are performed.

The reference design at Forsmark and its conformity to the design premises

The reference design is the result of the at present completed design step denominated Design step D2. The site-specific basis for the reference design is geotechnical information compiled in a site engineering report (SER). The information in the SER builds on the surface-based site investigations carried out at the Forsmark site and presented in the site descriptive model (SDM). The verification of the conformity of the reference design to the design premises is restricted by the currently anticipated uncertainties related to the SDM and SER.

The reference design is presented under the subtitles repository depth, deposition areas and deposition holes, other underground openings and engineered and residual materials. The repository depth is selected to conform to the design premises to find large enough volumes fulfilling the specific requirements on deposition holes and to avoid freezing of buffer and backfill and inadvertent human intrusion. The deposition areas and placement of the deposition holes shall conform to design premises for favourable and stable thermal, mechanical and hydrological conditions. The deposition tunnels as well as other tunnels, ramp and shafts are designed to conform to design premises regarding limitation of the EDZ. Finally, the amounts of engineered and residual materials in different parts of the underground facilities are estimated and compared to the acceptable amounts.

Reference methods

The reference methods for construction shall result in underground openings in conformity to the design premises for EDZ, geometry and inflow. The reference method for excavation of deposition tunnels is drill and smooth-blasting techniques. Experiences show that provided that proper control of drilling and blasting procedures are applied tunnels with acceptable EDZ and geometry can be constructed. The reference method for sealing the deposition tunnels is grouting the rock beyond the excavation face, i.e. pre-grouting, using low pH cement. Experiences from Äspö Hard Rock Laboratory (HRL) show that the inflow limitation imposed by the backfill can be achieved when detailed design procedures are combined with proper control of the grouting operation.

The reference method for excavating the deposition holes are full-face down-hole drilling techniques. Experiences from mechanical excavation methods show that it is possible to achieve an EDZ in conformity to the design premises. Based on experiences from Äspö HRL the geometrical variations will lie within the acceptable tolerances.

The reference methods also comprise methods for inspection. The method and criterion applied in selecting deposition hole positions will impact the conformity to the design premise to avoid shear displacements larger than the canister can withstand. The criterion to be applied states that fractures intersecting the deposition hole and the full perimeter of the tunnel and fractures intersecting five or more deposition holes are potentially critical and all affected deposition hole positions shall be rejected. It is foreseen that deposition holes having a potential for unacceptable inflows also are likely to be screened out by this criterion.

Initial state of the underground openings

The initial state of the underground openings refers to the properties of the underground openings at final installation of the buffer, backfill, closure or plugs. The presentation of the initial state comprises a summary of the site adapted design at Forsmark, the properties that can be expected based on the experiences from the reference methods and an assessment of the risk that the initial state of the underground openings does not conform to the design premises. In the risk assessment both site conditions, geohazards, and hazards associated with reference methods were considered. The assessment is at this stage qualitative. Both the likelihood of occurrence for identified hazards and the confidence in the monitoring and control programmes were considered. The risks were classified as *negligible* and/or *acceptable* or *significant* and/or *unacceptable*. No significant and/or unacceptable risks were identified. However, the assessment identified several issues of importance for the conformity to the design premises to be considered in the future development of the design and reference methods.

Sammanfattning

Rapporten ingår i en grupp av *Produktionsrapporter* som redovisar hur KBS-3-förvaret är utformat, producerat och kontrollerat. Gruppen av rapporter ingår i säkerhetsredovisningen för KBS-3-förvaret och förvarsanläggningen.

Rapporten redovisar indata om bergutrymmenas *initialtillstånd* för analysen av långsiktig säkerhet, **SR-Site**. Initialtillståndet avser egenskaperna hos bergutrymmena vid slutlig deponering, återfyllning eller förslutning. Dessutom ger rapporten information till driftsäkerhetsredovisningen, **SR-Drift**, om hur bergutrymmena ska byggas och kontrolleras.

Rapporten redovisar konstruktionsförutsättningarna och den metod som tillämpas för att utforma bergutrymmena och anpassa dem till förhållandena på platsen så att de överensstämmer med konstruktionsförutsättningarna. Den redovisar referensutförningen i Forsmark och dess överensstämmelse med konstruktionsförutsättningarna. Den beskriver också referensmetoderna som ska användas för att bygga och kontrollera de olika bergutrymmena. Slutligen redovisas bergutrymmenas initialtillstånd och dess överensstämmelse med konstruktionsförutsättningarna.

Konstruktionsförutsättningar för bergutrymmena

Konstruktionsförutsättningarna för bergutrymmena är baserade på föreskrifter, KBS-3-förvarets funktioner, konstruktionsstyrande fall från analysen av långsiktig säkerhet, konstruktionsstyrande händelser från redovisningen av driftsäkerhet, teknisk genomförbarhet och det planerade uppförandet.

Bergutrymmena ska rymma undermarksdelen av KBS-3-förvarsanläggningen. Bergutrymmena som sådana bidrar inte till KBS-3-förvarets säkerhet och har inga barriärfunktioner. Deponeringshålens inplacering med hänsyn till bergets termiska, hydrologiska och mekaniska egenskaper är dock viktig för utnyttjandet av berget som barriär, och således för förvarets säkerhet. Dessutom kan irreversibla förändringar i berget som omger berguttaget, dvs den skadade zonen (EDZ, excavation damaged zone) samt konstruktions- och kvarvarande material i berget påverka bergets och de tekniska barriärernas barriärfunktioner. Konstruktionsförutsättningar för placering av deponeringsområden och deponeringshål liksom restriktioner för konstruktions- och kvarlämnat material ges från analysen av den långsiktiga säkerheten. Bergutrymmena ska också överensstämma med konstruktionsförutsättningar från de tekniska barriärerna och pluggarna, och med konstruktionsförutsättningar relaterade till utbyggnad och drift av förvarsanläggningen.

Bergteknik

Bergteknikens mål är att säkerställa att den platsanpassade layouten samt uppförandet och de byggda bergutrymmena överensstämmer med konstruktionsförutsättningarna. SKB avser tillämpa den så kallade *observationsmetoden* för att anpassa bergutrymmenas layout och utbyggnad till den successivt utvecklade beskrivningen av platsen. Utformningen kommer alltid att baseras på den senaste platsbeskrivande modellen och överväga de mest troliga bergförhållandena liksom möjliga avvikelser varierande mellan de mest gynnsamma och de värsta tänkbara förhållandena. Tillämpning av observationsmetoden innebär att oönskade händelser som bidrar till risken för avvikelser från konstruktionsförutsättningarna identifieras, att modeller som förutsäger dessa händelser och beräknar parametrar som sen ska observeras under utbyggnaden fastställs, samt att åtgärdsplaner för att hantera tänkbara ogynnsamma förhållanden identifieras. Vid angivna milstolpar görs formella jämförelser mellan förutsättningarna för utformningen och de påträffade bergförhållandena.

Referensutformningen i Forsmark och dess överensstämmelse med konstruktionsförutsättningarna

Referensutformningen är resultatet av det för närvarande avslutade designskedet benämnt Designskede D2. De platsspecifika utgångspunkterna för referensutformningen är geoteknisk information sammanställd i en markteknisk undersökningsrapport (SER, site engineering report). Informationen i SER bygger på de markbaserade platsundersökningar som genomförts i Forsmark och som presenterats i den platsbeskrivande modellen (SDM, site descriptive model). Verifieringen av referensutformningens överensstämmelse med konstruktionsförutsättningarna begränsas av de för närvarande förutsedda osäkerheterna relaterade till SDM och SER.

Referensutformningen redovisas under rubrikerna förvarsdjup, deponeringsområden och deponeringshål, övriga bergutrymmen samt konstruktions- och kvarlämnat material. Förvarsdjupet är valt så att det överensstämmer med konstruktionsförutsättningar för att påträffa tillräckligt stora områden som uppfyller kraven på deponeringshål och för att undvika frysning av buffert och återfyllning samt oavsiktliga mänskliga intrång. Deponeringsområdena och placeringen av deponeringshål ska överensstämma med konstruktionsförutsättningar för gynnsamma och stabila termiska, mekaniska och hydrologiska förhållanden. Deponeringstunnlar liksom andra tunnlar, ramp och schakt är utformade så att de överensstämmer med konstruktionsförutsättningar för begränsning av EDZ. Slutligen beräknas mängderna konstruktions- och kvarlämnat material och jämförs med acceptabla mängder.

Referensmetoder

Referensmetoderna för utbyggnad ska resultera i bergutrymmen som överensstämmer med konstruktionsförutsättningarna för EDZ, geometri och inflöde. Referensmetoden för bergschakt av deponeringstunnlar är skonsam sprängning. Erfarenheter visar att förutsatt att lämplig styrning av borrh- och sprängförfarandet tillämpas så kan tunnlar med godtagbar EDZ och geometri byggas. Referensmetoden för att täta deponeringstunnlar är injektering framför tunnelfronten, dvs förinjektering, med låg-pH-cement. Erfarenheter från Äspölaboratoriet visar att den begränsning av inflödet som ges av återfyllningen kan åstadkommas när detaljerade utformningsrutiner kombineras med lämplig styrning av injekteringsverksamheten.

Referensmetoden för att bygga deponeringshål är nedåtriktad fullborrning. Erfarenheter från mekaniska bergschaktmetoder visar att det är möjligt att uppnå en EDZ som överensstämmer med konstruktionsförutsättningarna. Baserat på erfarenheter från Äspölaboratoriet kommer de geometriska variationerna att ligga inom de acceptabla toleranserna.

Referensmetoderna omfattar även metoder för kontroll. Metod och kriterium som tillämpas för att välja deponeringshålens placering påverkar överensstämmelsen med konstruktionsförutsättningen för att undvika skjuvrörelser större än de kapslarna kan motstå. Det kriterium som ska tillämpas anger att sprickor som skär deponeringshålet och deponeringstunnelns hela omkrets samt sprickor som skär fem eller fler deponeringshål är potentiellt riskfyllda och påverkade lägen för deponeringshål ska förkastas. Det förutses att deponeringshål med potential för icke tillåtna inflöden troligtvis också kommer att sällas bort av detta kriterium.

Bergutrymmenas initialtillstånd

Bergutrymmenas initialtillstånd avser egenskaperna vid slutlig installation av buffert, återfyllning, förslutning eller pluggar. Redovisningen av initialtillståndet omfattar en sammanfattning av den platsanpassade utformningen i Forsmark, egenskaper som kan förväntas baserat på erfarenheterna av referensmetoderna samt en analys av risken att bergutrymmenas initialtillstånd avviker från konstruktionsförutsättningarna. I riskanalysen övervägdes både platsförhållanden, oönskade bergförhållanden, och oönskade händelser relaterade till referensmetoderna. Analysen är i detta skede kvalitativ. Både sannolikheten att de identifierade oönskade händelserna ska inträffa och kontroll- och styrprogrammens tillförlitlighet övervägdes. Riskerna klassificerades som *försumbara* och/eller *acceptabla* eller *betydande* och/eller *oacceptabla*. Inga betydande och/eller oacceptabla risker identifierades. Analysen identifierade dock flera frågor med betydelse för överensstämmelsen med konstruktionsförutsättningarna som ska övervägas i den fortsatta utvecklingen av utformningen och referensmetoderna.

Contents

1	Introduction	11
1.1	General basis	11
1.1.1	This report	11
1.1.2	The design of the underground openings	11
1.1.3	The construction of the underground openings	11
1.2	Purpose, objectives and delimitations	12
1.2.1	Purpose	12
1.2.2	Objectives	12
1.2.3	Limitations	12
1.3	Interfaces to other reports included in the safety report	13
1.3.1	The safety report for the long-term safety	13
1.3.2	The safety report for the operational safety	13
1.3.3	The other production reports	13
1.4	Supporting site descriptive reports and underground openings design reports	14
1.4.1	Site descriptive reports	14
1.4.2	Underground design reports	14
1.5	Structure and content	14
1.5.1	Overview	14
1.5.2	Design premises	15
1.5.3	Rock engineering	15
1.5.4	Reference design and its conformity to the design premises	15
1.5.5	The methods for construction and inspection	15
1.5.6	Initial state of the underground openings	15
2	Design premises for the underground openings	17
2.1	General basis	17
2.1.1	Identification and documentation of design premises	17
2.1.2	Definitions, purpose and basic design	17
2.2	Required functions and design considerations	18
2.2.1	Functions of the underground openings in the KBS-3 repository	18
2.2.2	Design considerations	19
2.3	Design premises	19
2.3.1	Design premises related to the functions in the KBS-3 repository	20
2.3.2	Design premises from the engineered barriers and plug	22
2.3.3	Design premises related to production and operation	25
2.4	Design premises imposed by the underground openings	26
3	Rock engineering	27
3.1	General	27
3.2	The Observational Method	28
3.2.1	Description	28
3.2.2	Monitoring	30
3.3	Stepwise development of the underground facilities	30
3.4	Control programme	31
3.5	Documentation of as-built/initial-state conditions	31
4	The reference design at Forsmark and its conformity to the design premises	33
4.1	Repository depth	34
4.2	Deposition area – placement of deposition holes	34
4.2.1	Thermal conditions	34
4.2.2	Mechanical conditions	35
4.2.3	Hydrogeological conditions	37
4.3	Deposition holes	37
4.4	Deposition tunnels	39
4.5	Other underground openings	39

4.6	Engineered and residual materials	40
4.6.1	Rock support in underground openings	41
4.6.2	Grouting measures in underground openings	41
4.6.3	Quantities of engineered and residual materials	42
5	Reference methods	45
5.1	General basis	45
5.2	Reference methods used for the construction of deposition tunnels	45
5.2.1	The excavation damaged zone using drill and blast techniques	45
5.2.2	Geometrical tolerances	46
5.2.3	Tunnel floor contour	47
5.2.4	Grouting techniques and grouting results	47
5.2.5	Recess for the plug in deposition tunnels	48
5.2.6	Preparation of deposition tunnels	48
5.3	Reference methods used in construction of deposition holes	49
5.3.1	Excavation damaged zone using mechanical excavation techniques	49
5.3.2	Geometrical tolerances	50
5.3.3	Acceptable inflow	51
5.3.4	Methodology for accepting deposition holes on the basis of a discriminating fracture	51
5.3.5	Bevel in the upper part of the deposition hole	52
5.3.6	Preparation of deposition holes	52
5.4	Reference methods associated with other underground openings	54
6	Initial state of the underground openings	55
6.1	Introduction	55
6.2	Reference design at the Forsmark site	55
6.2.1	Repository depth and deposition areas	55
6.2.2	Deposition tunnels	56
6.2.3	Deposition holes	56
6.3	Geometry and properties of importance for the initial state of the engineered barriers	57
6.3.1	Buffer and deposition holes	57
6.3.2	Backfill and deposition tunnels	57
6.4	Uncertainty and risk relative to the initial state	58
6.4.1	General basis	58
6.4.2	Geohazards, design methodologies and reference methods	58
6.4.3	Risk matrix	60
6.4.4	Qualitative risk assessment of the initial state for repository depth and deposition areas	61
6.4.5	Qualitative risk assessment of the initial state for deposition tunnels	63
6.4.6	Qualitative risk assessment of the initial state for deposition holes	65
	References	69
Appendix A	Tabulation of data from measurements of as-built volumes in the tunnel excavated by means of smooth-blasting techniques at the Äspö Hard Rock Laboratory	71
Appendix B	Tabulation of data from measurements of cross-sectional centre points and diameters in 6 deposition holes drilled at the Prototype Repository at the Äspö Hard Rock Laboratory	73

1 Introduction

1.1 General basis

1.1.1 This report

This report presents the reference design, construction and initial state of the underground openings of the KBS-3 repository for spent nuclear fuel. It is included in a set of reports presenting how the KBS-3 repository is designed, produced and inspected. The set of reports is denominated *Production reports*. The Production reports and their short names used as references within the set are illustrated in Figure 1-1. The reports within the set referred to in this report and their full names are presented in Table 1-1.

This report is part of the safety report for the KBS-3 repository and repository facility, see **Repository production report**, Section 1.2. It is based on the results and review of the most recent long-term safety assessment and on the current knowledge and technology and results from research and development.

1.1.2 The design of the underground openings

The presented design of the underground openings presumes a repository based on the KBS-3 method with vertical deposition of canisters in individual deposition holes as further described in Chapter 3 in the **Repository production report**.

The reference design and construction methods presented in this report constitute an approach which is technically feasible. It is, however, foreseen that the design premises, the design as well as the presented methods for construction, test and inspection will be further developed and optimised before the actual construction of the KBS-3 repository facility commences. This is especially the case for the underground openings since both the design and the methods of construction require information on the conditions at repository depth. In this context it should be mentioned that there are alternative designs that conform to the design premises as well as alternative ways to construct the reference design. The safety assessment, as well as future safety assessments, may also result in up-dated design premises. SKB's objective is to continuously develop and improve both design and production and adapt them to the conditions at the selected site.

1.1.3 The construction of the underground openings

The construction of the underground openings is one of the main activities included in the operation of the KBS-3 repository facility. The principal layout of the underground openings as well as the sequence in which they are constructed are based on the planned operation of the KBS-3 repository facility presented in Section 4.1.4 in the **Repository production report**.

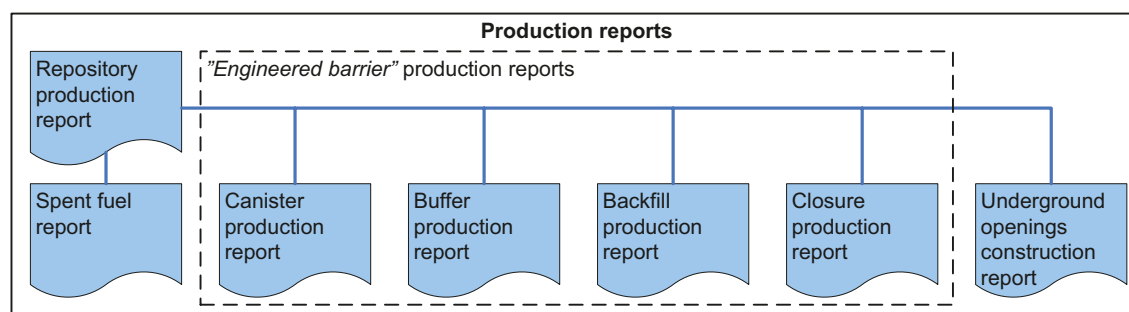

Figure 1-1. The reports included in the set of reports describing how the KBS-3 repository is designed, produced, tested and inspected.

Table 1-1. The reports within the set of Production reports referred to in this report.

Full title	Short name used within the Production line reports	Text in reference lists
Design and production of the KBS-3 repository	Repository production report	Repository production report, SKB 2010. Design and production of the KBS-3 repository. SKB TR-10-12, Svensk Kärnbränslehantering AB.
Design, production and initial state of the buffer	Buffer production report	Buffer production report, SKB 2010. Design, production and initial state of the buffer. SKB TR-10-15, Svensk Kärnbränslehantering AB.
Design, production and initial state of the backfill and plug in deposition tunnels	Backfill production report	Backfill production report, SKB 2010. Design, production and initial state of the backfill and plug in deposition tunnels. SKB TR-10-16, Svensk Kärnbränslehantering AB.
Design, production and initial state of the closure	Closure production report	Closure production report, SKB 2010. Design, production and initial state of the closure. SKB TR-10-17, Svensk Kärnbränslehantering AB.

1.2 Purpose, objectives and delimitations

1.2.1 Purpose

The purpose of this report is to describe how the underground openings of the KBS-3 repository are designed, constructed and inspected in a manner related to their importance for the safety of the KBS-3 repository. The report shall provide the information on the design, construction and initial state of the underground openings required for the long-term safety report, **SR-Site**, as well as the information on how to construct and inspect the underground openings required for the operational safety report, **SR-Operation**.

With this report SKB intends to present the design premises for the underground openings in the KBS-3 repository and demonstrate how the underground openings can be designed and constructed to conform to the stated design premises. The report shall present the reference design and construction methods and summarise the research and development efforts that supports that the underground openings can be constructed in conformity to the design premises.

1.2.2 Objectives

Based on the above purpose the objectives of this report are to present:

- the design premises for the underground openings,
- the reference design of the underground openings,
- the conformity of the reference design to the design premises,
- the reference methods for construction and inspection,
- the initial state of the underground openings, i.e. the expected result of the design and construction comprising as-built data on the properties taken credit for as contributing to, or affecting, the barrier functions of the rock and safety.

1.2.3 Limitations

This report includes design premises for the underground openings related to nuclear safety and radiation protection and to the dependable construction of the KBS-3 repository. The presented reference designs of the underground openings must conform to these design premises and consequently they have in most cases determined the design. Design premises related to other aspects, e.g. environmental impact, workers safety and cost-effectiveness, are only included if they have determined the design of the underground openings or the methods to construct them.

The report presents how the underground openings are constructed to conform to the stated design premises. Other aspects of the construction works, e.g. workers safety or logistics are reported elsewhere.

The report presents the reference design and methods. Alternative designs and planned developments of the design and methods are reported elsewhere.

This report also includes the design considerations made with respect to the application of best available nuclear safety and radiation protection technique. It describes the related design premises for the design and development of methods for construction and inspection of the underground openings. Motivations of the presented reference design and methods as the best available are reported elsewhere.

1.3 Interfaces to other reports included in the safety report

The role of the Production reports in the safety report is presented in Section 1.2 in the **Repository production report**. A summary of the interfaces to other reports included in the safety report is given below.

1.3.1 The safety report for the long-term safety

By providing a basic understanding of the repository performance over different time-periods and by the identification of scenarios that can be shown to be especially important from the standpoint of risk the long-term safety assessment provides feedback to the design of the engineered barriers and underground openings. The methodology used for deriving design premises from the long-term safety assessment is introduced in the **Repository production report**, Section 2.5.2. A more thorough description as well as the resulting design premises are given in the report “Design premises for a KBS-3V repository based on results from the safety assessment SR-Can and some subsequent analyses” /SKB 2009a/, hereinafter referred to as **Design premises long-term safety**. These design premises constitute a basic input to the design of the underground openings.

As stated in Section 1.2 this report shall provide information on the initial state of the underground openings and data concerning the design of the underground openings used in the assessment of the long-term safety.

1.3.2 The safety report for the operational safety

The objectives for the operational safety and radiation protection in the final repository facility and the general description of the facility and its main activities given in Chapters 3 and 5 of **SR-Operation** constitute an input to this report.

This report provides information to **SR-Operation** on the design of the underground openings and the technical systems used to construct and inspect them as well as instructions on where and when inspections shall be performed.

1.3.3 The other production reports

The **Repository production report** presents the context of the set of Production reports and their role within the safety report. It also includes definitions of some central concepts of importance for the understanding of the Production reports.

The **Repository production report** sets out the laws and regulations and demands from the nuclear power plant owners that are applicable to the design of a final repository for spent nuclear fuel. In addition, it describes the functions of a KBS-3-repository and how the safety is maintained by the barriers and their barrier functions. The report goes on to describe how design premises are derived from laws and regulations, owner demands and the iterative processes of design and safety assessment and design and technique development respectively. The starting point for the design premises presented in this report is the functions and design considerations introduced in the **Repository production report**, Chapter 3.

The design and production of the different engineered barriers and underground openings are inter-related. An overview of the design and production interfaces is provided in the **Repository production report**, Chapter 4. The design premises imposed by the engineered barriers for the underground openings stated in each of the “**Engineered barrier**” **production reports** are repeated in this report. The conformity of the reference designs of the underground openings to these design premises are verified in this report.

1.4 Supporting site descriptive reports and underground openings design reports

1.4.1 Site descriptive reports

SKB has undertaken surface-based site investigations with the purpose to develop a site descriptive model (SDM). A SDM is an integrated model for geology, thermal properties, rock mechanics, hydrogeology, hydrogeochemistry, bedrock transport properties and a description of the surface system. The SDM concluding the surface-based investigations at Forsmark is presented in /SKB 2008a/. It presents the integrated understanding of the Forsmark site at the completion of the surface-based investigations.

The SDM is comprehensive and serves the needs of many users, to extract data into parameters required for the design and layout of the underground openings a Site Engineering Report (SER) is developed. The SER comprise geological constraints and engineering guidelines for design issues related to the long-term safety of the repository as well as to operational requirements. The SER for the Forsmark site used in the current design stage, and supporting the design of the underground openings presented in this report, is presented in /SKB 2009c/. It is based on interpretation and evaluation of information in /SKB 2008/.

1.4.2 Underground design reports

SKB has compiled a steering document for the rock engineering works. The steering document includes the design premises, the design methodology to be applied and instructions for the design works. Further, it provides an overview of the documents the designers shall use and produce in their work. The steering document for the current design stage, denominated stage D2, is provided in /SKB 2007/.

Design stage D2 has been carried out in accordance to /SKB 2007/. The most significant results and SKB’s conclusions from the completed design D2 are presented in /SKB 2009b/. The report describes the proposed underground facility layout, the rock support and grouting in the different underground openings as well as the construction strategy and stepwise construction of the deposition areas. It also includes an assessment of uncertainty and risk related to the site and facility layout and design. The report is the main reference to the reference design and initial state of the underground openings presented in this report.

1.5 Structure and content

1.5.1 Overview

The general flow of information in the **Underground openings construction report** can be described as follows:

- design premises,
- rock engineering and design methodology,
- the reference design and its conformity to the design premises,
- methods for construction and inspection,
- initial state.

The listed bullets are further described in the following sections. In addition, the context of the report is presented in this chapter.

1.5.2 Design premises

The design premises set out the information required for the design. The design premises for the underground openings are presented in Chapter 2 of this report. The chapter starts with the definition of the underground openings and their purpose. After that follows a presentation of the functions the underground openings shall provide to contribute to the safety of the final repository and the considerations that shall be made in the design with respect to the application of a well-tried and reliable technique. Finally, the detailed design premises for the underground openings are given. They state the properties the reference design shall have to maintain the functions and to conform to the design considerations.

1.5.3 Rock engineering

Chapter 3 outlines the objectives of rock engineering and the methodology to be applied in the design works. The design methodology providing a framework for the design and construction of the underground openings as well as for adapting their layout to the conditions at the repository site is presented.

1.5.4 Reference design and its conformity to the design premises

In Chapter 4 the reference design of the underground openings is presented. It is based on the currently completed design stage for the final repository at the Forsmark site. The conformity of the reference design to each of the design premises presented in Chapter 2 is discussed and concluded on the basis of the current knowledge of the site.

1.5.5 The methods for construction and inspection

In Chapter 5 the reference methods for construction and inspection of the underground openings are presented. The presentation includes the current state of development and results from demonstrating their performance relative to the design premises.

1.5.6 Initial state of the underground openings

In Chapter 6, the initial state of the underground openings and the conformity of the constructed underground openings to the design premises related to the long-term safety of the repository is presented. The chapter comprises conclusions regarding the layout and its adaptation to the site conditions and the capability of the reference methods to result in underground openings that conform to the specifications. It also presents an assessment of the risk of nonconformity to the design premises.

2 Design premises for the underground openings

In this chapter the design premises for the underground openings are presented. They comprise the functions and properties the underground openings shall sustain in the KBS-3 repository and premises for their design. *The required functions and design premises are written in italics.*

2.1 General basis

2.1.1 Identification and documentation of design premises

The methodology to derive, review and document design premises is presented in the **Repository production report**, Chapter 2. The design premises are based on:

- international treaties, national laws and regulations,
- the functions of the KBS 3 repository,
- the safety assessment,
- technical feasibility,
- the planned production.

The **Repository production report**, Section 2.2 includes a presentation of the laws and regulations applicable for the design of a final repository. Based on the treaties, laws and regulations SKB has substantiated functions and considerations as a specification of the KBS-3 repository, and as guidelines for the design of its engineered barriers and underground openings. In Section 3.7.2 of the **Repository production report** the functions and properties that the underground openings shall sustain in order to contribute to the functions of the KBS-3 repository are presented. Section 3.9 of the **Repository production report** introduces the design considerations to be applied in the design work. The presented functions of the underground openings and the considerations that shall be applied in the design work are repeated in Section 2.2 in this report.

The design premises related to the functions of the underground openings in the KBS-3 repository are based on the results from the latest long-term safety assessment and some subsequent analyses. These design premises for the underground openings are provided in **Design premises long-term safety**, and presented in Section 2.3.1 in this report.

Design premises related to technical feasibility refer to the properties the underground openings shall have to fit, and work, together with the engineered barriers and other parts of the final repository during the production. The general approach to substantiate this kind of design premises is presented in Section 2.5.1 in the **Repository production report** and the interfaces to the engineered barriers and other parts in the production are summarised in Section 4.9.2 in the **Repository production report**. In this report these design premises from the engineered barriers and plugs are presented in Section 2.3.2.

Finally, design premises related to the operation of the KBS 3 repository facility and construction of the underground openings are presented in Section 2.3.3 in this report. The methodology to substantiate these kinds of design premises is presented in Section 2.5.4 in the **Repository production report**.

2.1.2 Definitions, purpose and basic design

The underground openings are the cavities constructed in the rock that are required to accommodate the sub-surface part of the final repository facility. The underground openings comprise:

- the actual geometry and location of the cavities,
- the rock surrounding the openings that is affected by the rock construction works, and
- engineered materials for sealing and rock reinforcement, and residual materials from performance of activities in the final repository facility which, at deposition, backfilling or closure, remain in and on the rock that surrounds the openings.

The underground openings as such do not contribute to the safety of the KBS-3 repository and do not have any barrier functions. However, the locations of the deposition areas and deposition holes with respect to the thermal, hydrological, mechanical and chemical properties of the rock are important for the utilisation of the rock as a barrier and thus for the safety of the repository. Furthermore, disturbances on the rock surrounding the tunnels, i.e. the excavation damaged zone (EDZ), and engineered and residual materials that remain in the rock may impact the barrier functions of the rock and/or the engineered barriers, and must therefore be known when assessing the safety of the repository.

The underground openings shall accommodate the sub-surface part of the final repository facility. The principal layout of the KBS-3 repository facility and the nominal dimensions of the underground openings have been decided considering operational requirements, activities in the KBS-3 repository facility and the dimensions of the engineered barriers and plugs.

2.2 Required functions and design considerations

In this section, the functions and design considerations for the underground openings are presented. They are based on the functions of the KBS-3 repository presented in Section 3.1.2 in the **Repository production report** and have been divided into:

- functions and properties that the underground openings shall sustain in order for the final repository to maintain its safety (Section 2.2.1) and
- issues that shall be considered when developing the layout and design of the underground openings and methods for excavation, grouting, rock reinforcement and inspection (Section 2.2.2).

2.2.1 Functions of the underground openings in the KBS-3 repository

In order for the KBS-3 repository to be able to accommodate all spent nuclear fuel from the currently approved Swedish nuclear power programme the underground openings shall:

- *accommodate the sub-surface part of the final repository facility with the number of approved deposition holes that are required to deposit all canisters with spent nuclear fuel.*

In order for the final repository to contain, prevent or retard the dispersion of radioactive substances, the rock shall provide stable and favourable conditions for the engineered barriers so that their barrier functions can be sustained for as long as necessary bearing in mind the radiotoxicity of the spent nuclear fuel. Should the containment provided by the canister be breached, the rock will contribute to the safety of the final repository by preventing or retarding the dispersion of radioactive substances. In order for the rock to sustain its barrier functions and to maintain the multi-barrier principle, the underground openings shall be adapted to the conditions at the repository site so that:

- *thermally favourable conditions are provided and the containment of radioactive substances can be sustained over a long period of time,*
- *mechanically stable conditions are provided and the containment of radioactive substances can be sustained over a long period of time,*
- *favourable hydrologic and transport conditions are provided and the containment, prevention or retardation of dispersion of radioactive substance can be sustained over a long period of time,*
- *chemically favourable conditions are provided and the containment, prevention or retardation of dispersion of radioactive substances can be sustained over a long period of time.*

In order for the KBS-3 repository to maintain the multi-barrier principle and have several barriers which individually and together contribute towards maintaining the barrier functions, the underground openings shall:

- *be designed so that they do not significantly impair the barrier functions of the rock or the engineered barriers.*

In the design of the KBS-3 repository unintentional intrusion shall be considered so that the repository site after closure of the repository facility can be utilised without compromising the freedom

of action, needs and aspirations of future generations. With respect to this and the fact that the final repository shall isolate the spent fuel from the environment at the surface:

- *the repository depth shall be selected with respect to the human activities which, based on present living habits and technical prerequisites, may occur at the repository site.*

In order for the barrier system of the final repository to withstand failures and conditions, events and processes that may impact their functions, the underground openings shall:

- *allow the deposition of canister and buffer with the desired barrier functions,*
- *allow the installation of backfill and closure with the desired barrier functions.*

The latter is also required in order for the barriers of the closed final repository to be passive, and in order for it to be technically feasible to close and seal the final repository facility after the deposition has been carried out.

For the nuclear operation of the final repository facility to be safe, the underground openings shall:

- *be designed so that breakdowns and mishaps in connection with the nuclear operations are prevented.*

The underground openings shall also be designed so that other activities in the final repository facility can be carried out in a safe way.

2.2.2 Design considerations

In this section the design considerations that shall be regarded in the design of underground openings and the development of construction methods as well as the methods for monitoring and inspections of the underground openings are presented.

The system of barriers and barrier functions of the final repository shall withstand failures and conditions, events and processes that may impact their functions. Hence the following shall be considered.

- *Excavation, sealing and rock reinforcement shall be based on well-tried or tested technique.*

The construction and inspections of the underground openings shall be dependable, and the following shall be considered.

- *The underground openings shall be designed and constructed using methods so that they, with reliability, acquire the specified properties.*
- *The properties of the underground openings shall be possible to inspect against specified criteria.*

Further, environmental impact such as noise and vibrations, emissions to air and water, impact on groundwater and consumption of material and energy shall also be considered in the design. Methods to construct and inspect the underground openings must also conform to regulations for occupational safety. Requirements related to these aspects can generally be met in a number of alternative ways for designs that conform to the safety and radiation protection requirements.

2.3 Design premises

In this section the design premises for the underground openings are given. The design premises constitute a specification for the design of the underground openings. The design premises comprise the properties to be designed and premises for the design such as quantitative information on features, performance, events, loads, stresses, combinations of loads and stresses and other information, e.g. regarding environment or adjacent systems, which form a necessary basis for the design.

The design premises are based on the functions the underground openings shall have in the final repository presented in Section 2.2.1 and the design considerations presented in Section 2.2.2. They are also based on, and constitute a concise summary of, the current results of the design process with its design–safety assessment and design–technical feasibility iterations, see Section 2.5.1 in the **Repository production report**.

The design premises given as feedback from the long-term safety assessment are compiled in **Design premises long-term safety**.

The design premises given as feedback from the technical development are based on the reference designs of the other parts of the KBS-3 repository and the plans for the main activities and operation of the KBS-3 repository facility presented in Section 4.1.4 in the **Repository production report**.

2.3.1 Design premises related to the functions in the KBS-3 repository

The design premises for the underground openings related to their functions in the KBS-3 repository are compiled in Table 2-1 (A-C). In the left hand column of the table the functions which form the basis for the design premises and that were presented in Section 2.2.1 are repeated, the middle column contains the underground opening property to be designed and adapted to the site and the right hand column gives the design premises as stated in **Design premises long-term safety**.

Table 2-1. The functions, the related properties and parameters to be designed and the design premises for the underground openings.

A. Repository depth and deposition areas

Function	Property to be designed	Design premises long-term safety
<i>The underground openings shall accommodate the sub-surface part of the final repository facility with the number of approved deposition holes that are required to deposit all canisters with spent nuclear fuel.</i>	Deposition areas – <i>utilised rock domains, distances between deposition holes and loss of deposition hole positions.</i> Repository depth	<i>The repository volumes and depth need to be selected where it is possible to find large volumes of rock fulfilling the specific requirements on deposition holes.</i> <i>The requirements on deposition holes include acceptable thermal, mechanical, hydrological and transport conditions.</i> <i>The repository shall have sufficient capacity to store 6,000 canisters.¹</i>
<i>The underground openings shall be adapted to the rock so that thermally favourable conditions are provided and the containment of radioactive substances can be sustained over a long period of time.</i>	Repository depth	<i>With respect to potential freezing of buffer and backfill, surface erosion and inadvertent human intrusion, the depth should be considerable. Analyses in the SR-Can assessments corroborate that this is achieved by prescribing the minimum depth to be as specified for a KBS-3 repository, i.e. at least 400 m.</i>
<i>The repository depth shall be selected with respect to the human activities which, based on present living habits and technical prerequisites, may occur at the repository site.</i>		
<i>The underground openings shall be adapted to the rock so that chemically favourable conditions are provided and containment, prevention or retardation of dispersion of radioactive substances can be sustained over a long period of time.</i>	Deposition areas – <i>utilised rock domains, hydrogeochemical conditions.</i> Repository depth	<i>Reducing conditions;</i> <i>Salinity; TDS limited</i> <i>Ionic strength; $[M^{2+}] > 1 \text{ mM}$</i> <i>Concentrations of K, HS⁻, Fe; limited</i> <i>pH; pH < 11</i> <i>Avoid chloride corrosion; pH > 4 or $[Cl^-] < 3 \text{ M}$.</i>

¹ This is not a design premise from the long-term safety. It is an estimation based on the number of spent fuel assemblies to be encapsulated and deposited.

B. Deposition holes

Function	Property to be designed	Design premises long-term safety
<i>The underground openings shall be adapted to the rock so that thermally favourable conditions are provided and the containment of radioactive substances can be sustained over a long period of time.</i>	Deposition holes – <i>distances between deposition holes.</i>	<i>The buffer geometry (e.g. void spaces), water content and distances between deposition holes should be selected such that the temperature in the buffer is <100°C.</i>

Function	Property to be designed	Design premises long-term safety
The underground openings shall be adapted to the rock so that mechanically stable conditions are provided and the containment of radioactive substances can be sustained over a long period of time.	Deposition holes – respect distance to deformation zone.	Deposition holes are not allowed to be placed closer than 100 m to deformation zones with a trace length longer than 3 km.
	Deposition holes – intersecting fractures (mechanical properties).	Deposition holes should, as far as reasonably possible, be selected such that they do not have potential for shear larger than the canister can withstand. To achieve this, the EFPC ¹ criterion should be applied in selecting deposition hole positions.
The underground openings shall be adapted to the rock so that favourable hydrologic and transport conditions are provided and the containment, prevention or retardation of dispersion of radioactive substances can be sustained over a long period of time.	Deposition holes – inflow	The total volume of water flowing into a deposition hole, for the time between when the buffer is exposed to inflowing water and saturation, should be limited to ensure that no more than 100 kg of the initially deposited buffer material is lost due to piping/erosion. This implies, according to present knowledge, that this total volume of water flowing into an accepted deposition hole must be less than 150 m ³ .
	Deposition holes – intersecting fractures (hydrogeological properties).	Fractures intersecting the deposition holes should have a sufficiently low connected transmissivity (specific value cannot be given at this point). This criterion is assumed to be fulfilled if the conditions regarding inflow to deposition holes are fulfilled.
The underground openings shall be designed so that they do not significantly impair the barrier functions of the rock or the engineered barriers.	Deposition holes – transmissivity of EDZ.	Before canister emplacement, the connected effective transmissivity integrated along the full length of the deposition hole wall and as averaged around the hole, must be less than 10 ⁻¹⁰ m ² /s.

¹ EFPC stands for *Extended Full Perimeter Intersection Criterion*, see Section 4.2.2 and Figure 4-2.

C. Deposition tunnels, other underground openings and engineered and residual materials

Function	Property to be designed	Design premises long-term safety
The underground openings shall be designed so that they do not significantly impair the barrier functions of the rock or the engineered barriers.	Deposition tunnels – transmissivity of EDZ.	Excavation-induced damage should be limited and not result in a connected effective transmissivity, along a significant part (i.e. at least 20–30 m) of the disposal tunnel and averaged across the tunnel floor, higher than 10 ⁻⁸ m ² /s. Due to the preliminary nature of this criterion, its adequacy needs to be verified in SR-Site.
	Shafts and ramp, rock caverns and tunnels other than deposition tunnels – transmissivity of EDZ.	Below the location of the top sealing, the integrated effective connected hydraulic conductivity of the backfill in tunnels, ramp and shafts and the EDZ surrounding them must be less than 10 ⁻⁸ m/s. This value need not be upheld in sections where e.g. the tunnel or ramp passes highly transmissive zones. There is no restriction on the hydraulic conductivity in the central area.
	Grouting and rock reinforcement in deposition tunnels – extent/design, leaching product of grouting material.	Only low pH materials (pH<11) No continuous shotcrete Continuous grouting boreholes outside tunnel perimeter should be avoided.
	Grouting and rock reinforcement in boreholes shafts and ramp, rock caverns and tunnels other than deposition tunnels – leaching product of grouting material.	Only low pH (<11) materials are allowed below the level of the top seal.
	Engineered and residual materials in all underground openings – amounts and composition.	Other residual materials must be limited – but the amounts considered in SR-Can are of no consequence.

2.3.2 Design premises from the engineered barriers and plug

In this section the design premises for the underground openings imposed by the engineered barriers and plugs related to technical feasibility are presented. Note that interdependencies between the underground openings and other parts of the final repository occurring after the initial state are considered in the design premises related to the functions of the underground openings in the final repository, presented in Table 2-1.

Buffer

A background to the design premises imposed for the deposition holes by the buffer is given in the **Buffer production report**, Section 2.4.1. The deposition hole shall allow dependable installation of the buffer according to specification. To achieve this, the design premises presented in Table 2-2 and illustrated in Figure 2-1 are imposed by the buffer for the deposition holes.

The stated deviations in radii include all possible causes, e.g. alignment, straightness, displacements and rock fall out. The stack of bentonite blocks is positioned so that the centre line of the blocks coincides with the average vertical centre line of the deposition hole.

Backfill

A background to the design premises imposed for the deposition tunnels by the backfill is given in the **Backfill production report**, Section 2.4.1. The deposition tunnels shall allow dependable installation of the backfill according to specification. To achieve this, the design premises presented in Table 2-3 are imposed by the backfill for the deposition tunnels.

Plug in deposition tunnels

A background to the design premises imposed for the deposition tunnels by the plug is given in the **Backfill production report**, Section 2.6.1. The deposition tunnels shall allow dependable installation of the plug in deposition tunnels according to specification. To achieve this, the design premises presented in Table 2-4 are imposed by the plug for the deposition tunnels. The deposition tunnels shall conform to these design premises during the operational phase of the final repository facility.

Table 2-2. Design premises imposed by the buffer for the deposition holes.

Required property	Design premises
The diameter and height of the deposition hole shall allow sufficient room to accommodate the buffer and canister.	<p><i>Nominal thickness of the buffer around, below and above the canister (0.35 m; 0.5 m and 1.5 m).</i></p> <p><i>Nominal dimensions of the canister, Canister production report, Section 3.2.3.</i></p> <p><i>Resulting diameter 1.75 m</i></p> <p><i>Resulting height 6.68 m</i></p>
The deposition hole bottom inclination shall with respect to the dimensions of the buffer blocks allow deposition of the canister.	<p><i>The inclination over the part of the cross section where the bottom buffer block is placed shall be less than 1/1,750.</i></p>
Variations in deposition hole geometry must not be larger than to allow deposition of buffer according to specification.	<p><i>In that part of the deposition hole where buffer is going to be installed the maximum area in each horizontal cross section must not exceed the nominal cross section by more than 7%.</i></p> <p><i>In that part of the deposition hole where buffer is going to be installed the diameter shall be at least 1.745 m. The nominal diameter is 1.75 m.</i></p> <p><i>From the height of the buffer block on top of the canister to the bottom of the deposition hole the radius from a vertical line in the centre of the deposition hole shall be at least 0.84 m.</i></p> <p><i>From the height of the buffer block on top of the canister to the bottom of the deposition hole the radius from a vertical line in the centre of the deposition hole must not exceed 0.925 m.</i></p>

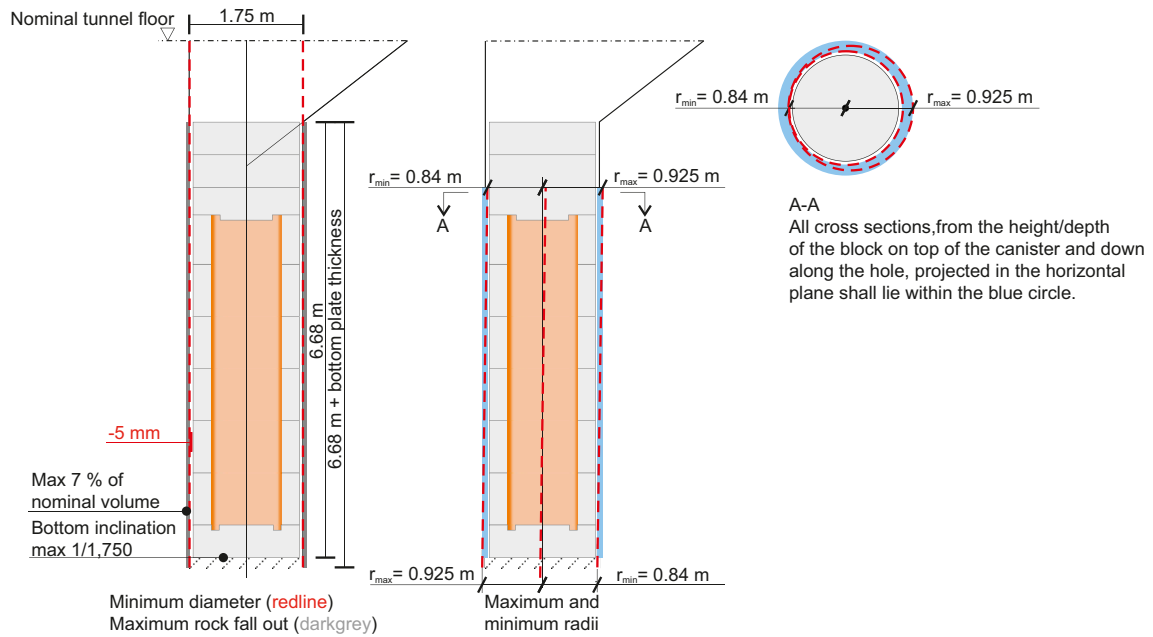

Figure 2-1. Nominal deposition hole geometry (black thin line) and acceptable deviations in geometry (red dotted line). The scale of the deviations in section A-A is enlarged with a factor of two. The acceptable deviations concern the part of the deposition hole where the buffer is going to be installed. The top of the deposition hole is designed with respect to operational requirements.

Table 2-3. Design premises imposed by the backfill for the deposition tunnels.

Required property	Design premises
<p>The deviations of floor and wall surfaces in deposition tunnels from the nominal must be limited in order to allow backfilling according to specification.</p>	<p>For each blast round the total volume between the rock wall contour and the nominal contour of the deposition tunnel shall be less than 30% of the nominal tunnel volume.</p> <p>The maximum cross section shall be less than 35% larger than the nominal cross section.</p> <p>To achieve a dependable backfill installation the tunnel floor must be even enough for the backfill installation equipment to drive on it.</p> <p>Underbreak is not accepted.</p> <p>See Figure 2-2</p>
<p>The floor and wall surfaces in deposition tunnels shall for the most part consist of rock surface so that the backfill will be in direct contact with the rock.</p>	<p>Limited areas may be covered with construction materials. The areas must not extend over the full tunnel width.</p>
<p>The seepage into deposition tunnels during backfill installation and saturation must not significantly impair the backfill barrier functions.</p>	<p>Based on current experiences the maximum distributed inflow to the deposition tunnel is set to be less than or equal to 1.7 l/min 100 m (based on 5 l/min in a 300 m long deposition tunnel) and the maximum point inflow less than or equal to 0.1 l/min.</p>

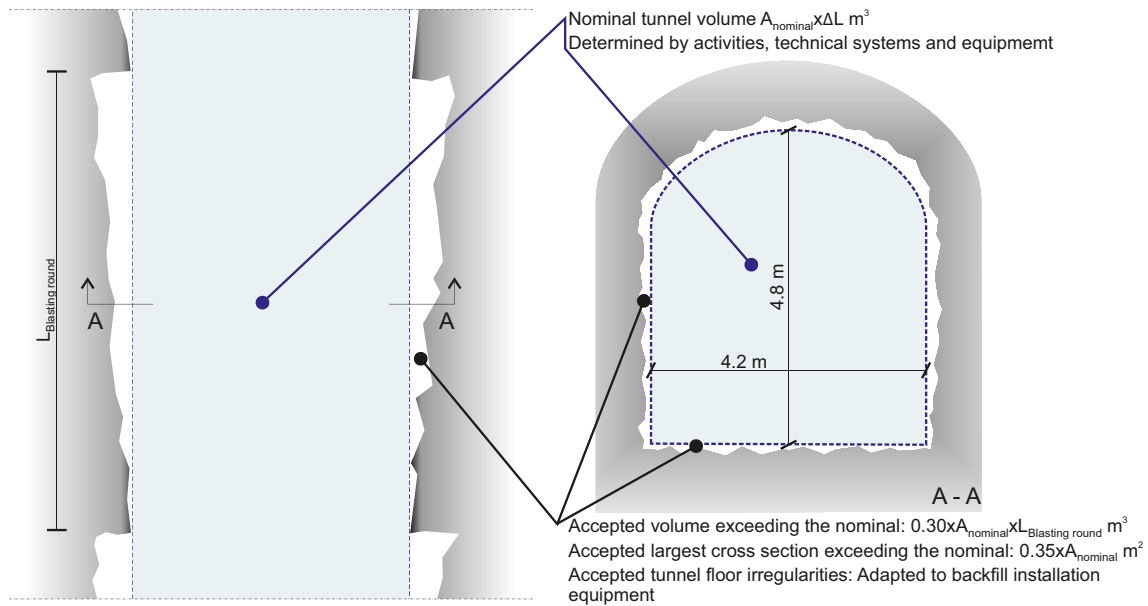

Figure 2-2. Nominal tunnel geometry and acceptable volume of rock fall out and irregularities in the tunnel walls.

Table 2-4. Design premises imposed by the plug for the deposition tunnels.

Required property	Design premises
<i>Inflow/seepage of water to the part of the deposition tunnel where the plug shall be installed must be limited since excessive water inflow during construction of the concrete plug may impact the properties of the finished plug.</i>	<i>The accepted inflow is not determined at this stage of development.</i>
<i>A recess for foundation of the concrete plug shall be prepared in the rock.</i>	<i>Geometry of the reference concrete plug.</i>
<i>Anchoring for structures for the installation of the plug shall be prepared in the rock.</i>	<i>Geometry and loads according to the reference design of the plug.</i>
<i>The strength and properties of the rock in the area of the location of the plug shall be suitable for construction of the recess for the concrete plug and anchoring of temporary structures.</i>	<i>The forces transmitted from the plug to the rock.</i>

Closure

The reference design of the closure is presented in the **Closure production report**, Sections 3.1 to 3.4. In the reference design the main and transport tunnels and ramp and shafts below the top seal, i.e. below the elevation of -200 m , are filled with clay. The remaining cavities, i.e. caverns in the central area and ramp and shaft above the elevation of -200 m , are filled with rock fill. The reference design for clay closure is a block-concept similar to the backfill in deposition tunnels but with higher acceptable hydraulic conductivity. Accordingly, the closure of these parts of the repository imposes similar design premises for the underground opening in question, as the backfill does for the deposition tunnels. However, the acceptable variations will deviate from those imposed by the backfill on deposition tunnels. The acceptable variations in tunnel and shaft volumes will be determined before excavating these volumes, in parallel to the development of the closure design. Most probably larger deviations than in the deposition tunnels can be accepted. At this stage of development the properties to be designed and qualitative design premises are given in Table 2-5.

In addition, to limit the probability that closed investigation boreholes will form water conductive channels that may jeopardise the barrier functions of the rock the locations of the boreholes have to be considered in the layout of the final repository facility. It must be avoided that boreholes connected to the surface intersect underground openings. Further, deposition holes must not be intersected by any investigation boreholes.

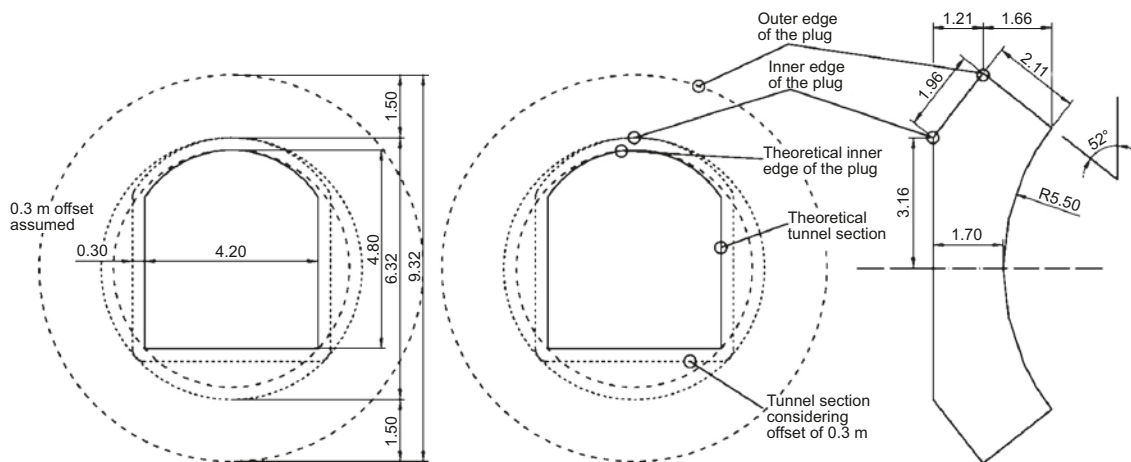

Figure 2-3. Nominal geometry for the plug.

Table 2-5. Design premises imposed by the closure in underground openings that will be backfilled with clay.

Required property	Design premises
<i>The floor and wall surfaces of underground openings where the closure consist of clay material must be even enough to allow backfilling according to specification.</i>	<i>Restrictions on volume between the rock wall contour and the nominal contour.</i>
<i>The seepage into the underground openings during installation and saturation of the closure must not significantly impair the closure barrier functions.</i>	<i>Underbreak is not allowed.</i>
<i>For a backfilled underground opening to maintain its function, the floor and wall surfaces of the underground opening shall for the most part consist of rock surface so that the closure material will be in direct contact with the rock.</i>	<i>Acceptable inflow preliminary set to the levels stated in Section 2.3.3.</i>
	<i>Currently, no design premise has been set for this property. However, roads and other structures installed to facilitate the operation must be removed before the start of closure activities.</i>

Plugs in underground openings other than deposition tunnels

There will be plugs also in tunnels other than deposition tunnels, ramp and shafts. The purposes of these plugs can be to separate filled and closed underground openings from underground openings that remain to close, to cut of conductive features in the rock or to facilitate the installation of the closure, see the **Closure production report**, Section 3.6. It is anticipated that these plugs will impose similar design premises for the underground openings as the plugs in deposition tunnels. The design premises will be determined in parallel to the detailed design of the plugs.

2.3.3 Design premises related to production and operation

In this section the design premises for the underground openings related to their construction and the operation of the KBS-3 repository facility are given. In addition to the functions and design considerations presented in Section 2.2, they are based on how the main activities in the repository facility are planned to be carried out and on SKB's objective to minimize radiation doses during the operation of the KBS-3 repository facility presented in **SR-Operation**, Chapters 1, 3 and 5.

The layout of the underground openings, the grouting and rock reinforcement shall be designed so that breakdowns and mishaps in connection to the nuclear operation are prevented. Further, the design of the underground openings shall allow activities in the repository facility to be carried out in a safe and cost-effective way with acceptable impact on the environment and on groundwater levels. With respect to this the maximum allowed inflow to shafts, rock caverns and tunnels other than deposition tunnels is preliminary set to $Q \leq 10$ litre/min 100 m. Design premises related to nuclear operations are given in Table 2-6.

Table 2-6. Design premises for the underground openings related to the nuclear operation of the final repository facility.

Design consideration or function	Required property	Design premises
<p><i>The underground openings shall be designed so that breakdowns and mishaps in connection with the nuclear operations are prevented.</i></p> <p><i>The underground openings shall allow the deposition of canister and installation of buffer with desired barrier functions.</i></p>	<p><i>The placement of the deposition hole within the deposition tunnel cross section shall allow deposition of buffer and canister.</i></p>	<p><i>Deposition tunnel geometry.</i></p> <p><i>Installation equipment for buffer.</i></p> <p><i>Deposition machine.</i></p>
<p><i>The underground openings shall be designed so that breakdowns and mishaps in connection with the nuclear operations are prevented.</i></p>	<p>Underground opening stability, rock reinforcement in underground openings where the canister is handled – extent/design</p>	<p><i>The frequency of the event: “Rock falling on the canister and damaging it so it is no longer fit for deposition.” must not exceed 10^{-3}.</i></p>

2.4 Design premises imposed by the underground openings

The underground openings do not impose any design premises for the engineered barriers or other parts in the final repository.

The construction of the underground openings may, due to the occurrence of vibrations, impose that there shall be a respect distance between construction works and completed parts of the final repository, i.e. deposition holes where installation of the buffer and deposition of the canister is completed and backfilled deposition tunnels.

3 Rock engineering

3.1 General

The design premises for the underground openings were presented in Chapter 2. The objectives of rock engineering are to ensure that the site-adapted layout of the repository facility, as well as the construction and as-built underground openings, conform to those design premises.

Engineering projects are divided into design and construction. The design is carried out successively as more detailed conditions for the site becomes available. The current reference design – D2 /SKB 2009b/ – documents the preliminary design for the underground part of the repository facility based on the site conditions given in SDM-Site /SKB 2008/. The design preceding the construction, i.e. the detailed design, will deliver the specifications and engineering drawings for the layout and underground openings that will form the Final repository.

In all phases of underground design and construction, uncertainties with regard to site conditions must be anticipated. In order to establish a final layout for deposition tunnels and deposition holes, a large volume of rock will have to be characterised, see Figure 3-1. The uncertainties that will influence the final layout are the spatial location and variability of the geological setting and the rock mass response to excavation, rock support and grouting measures. These uncertainties and the scale of the repository volume emphasize that the methodology used to adapt the final layout of the repository to the site conditions must be integrated with the construction activities required to develop the repository. The methodology that SKB will use for adapting the layout of the repository to the site conditions is based on the Observational Method /Peck 1969/.

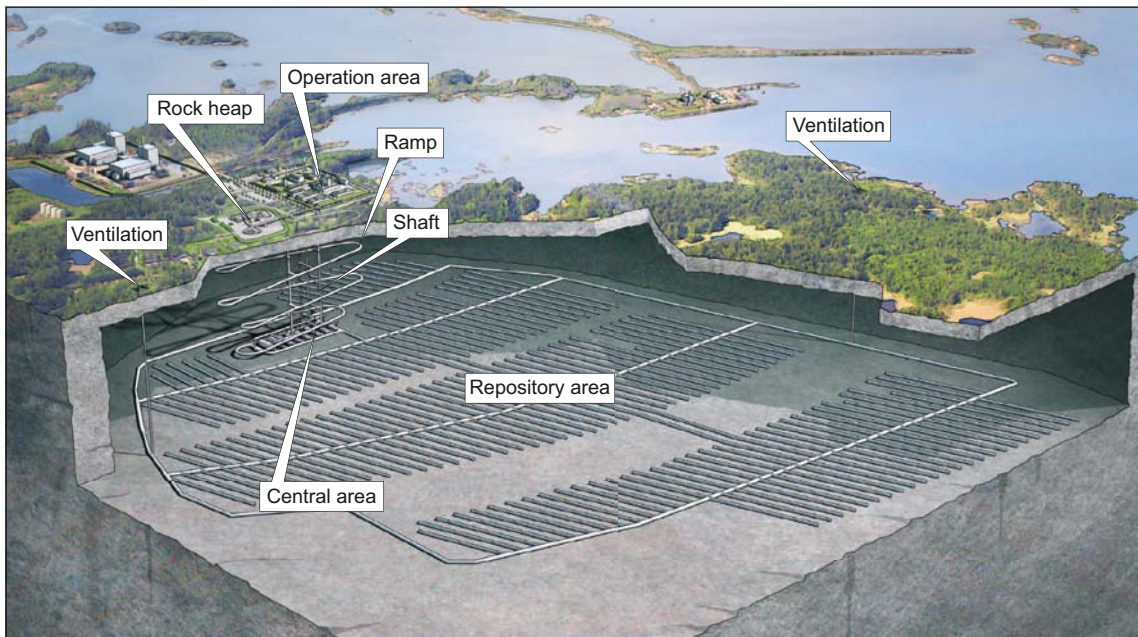

Figure 3-1. Illustration of the layout contained in the D2 Reference Design for a final repository facility in Forsmark.

3.2 The Observational Method

The *Observational Method* is a risk-based approach to underground design and construction that employs adaptive management, including monitoring and measurement techniques /SKB 2009b/. The Observational Method was developed for large scale projects where the complexity and spatial variability of the geological setting prohibits knowing the detailed site conditions prior to construction. Consequently the Observational Method must provide for the collection of site information in conjunction with construction.

3.2.1 Description

The formal requirements of the Observational Method are found in the European standard for construction and geotechnical design, Eurocode 7 /EN 1997-1:2004, Section 2.7/. The main elements of the Observational Method are:

1. **acceptable limits of behaviour** shall be established,
2. the **range of possible behaviour** shall be assessed and it shall be shown that there is an acceptable probability that the actual behaviour will be within the acceptable limits,
3. a **plan for monitoring the behaviour** shall be devised, which will reveal whether the actual behaviour lies within the acceptable limits,
4. the **response time of the monitoring** and the procedures for analysing the results shall be sufficiently rapid in relation to the possible evolution of the system,
5. a **plan of contingency actions** shall be devised which may be adopted if the monitoring reveals behaviour outside acceptable limits.

SKB will apply the Observational Method for adaptation of the repository to the site conditions, so that the as-built layout and underground openings conform to the design premises. Application of the Observational Method requires the following.

- (1) One must be able to define an action plan for possible adverse conditions. This implies that **the method cannot be used if a predictive model for the behaviour cannot be developed**, i.e. one must be able to establish a model that can calculate the parameters that will subsequently be observed during construction.
- (2) **One must be able to monitor the parameters that can predict behaviour**. This is not a trivial problem as often we can measure what we cannot calculate and vice versa. This means that the monitoring plan must be chosen very carefully with a good understanding of the significance to the problem. Erroneous preconceptions about the dominant phenomena that control the behaviour can lead to choosing irrelevant observational parameters.

The detailed design will be based on the SDM and consider the most likely ground conditions as well as possible deviations ranging from most favourable to worst conceivable conditions. The application of the Observational Method is based on identification of *hazards*, i.e. uncertainties that may contribute to the risk for nonconformity of the layout and underground openings to the design premises. The preliminary design D2 identified the uncertainties in the site geological conditions, termed *geohazards*, that could impact the design and repository layout. The impact of these geohazards was assessed in the preliminary design using qualitative risk assessment methodologies. A similar procedure will be adopted during the detailed design.

The Observational Method is a formal design procedure requiring a formal comparison, at designated milestones, of the design assumptions and encountered ground conditions. The comparisons shall assess if the layout used to accommodate the site conditions satisfies the design premises. If deviations from the design should occur a formal review by the Safety in Project (SIP) team is required. This implies that parameters used to monitor the conformance of the layout to the design premises must be clearly identified and acceptance criteria (threshold levels) quantified beforehand. SKB's application of the Observational Method is illustrated in Figure 3-2.

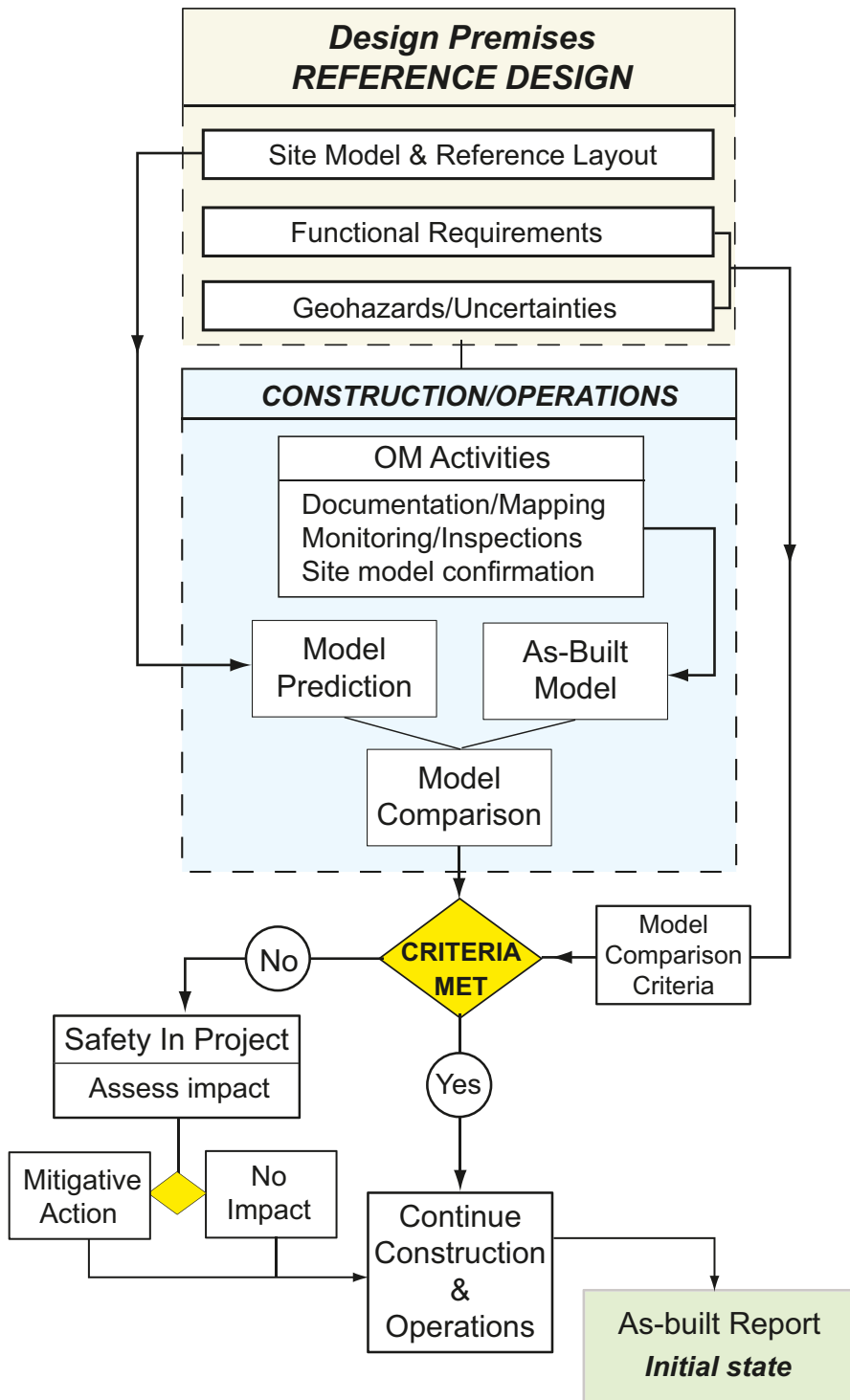

Figure 3-2. Illustration of SKB's implementation of the Observational Method for repository design.

3.2.2 Monitoring

The monitoring activities required for implementing the Observational Method are dependent on the repository functional requirements and the particular geohazard being monitored. The details of the monitoring programme will be developed successively. For example /SKB 2009b/ identified the frequency of water bearing fractures and the associated inflows in fracture domain FFM02 as the geohazard with the greatest consequence for the repository access. Therefore the groundwater inflows to the access ramp and the associated drawdown of the groundwater head around the excavation require monitoring. In addition, to verifying the SDM, an assessment of the fracture orientations on which the inflows are occurring and their spatial distribution is also required. The groundwater conditions encountered will be documented using formal as-built reporting guidelines. The as-built conditions will be compared to the predictions made prior to the beginning of construction. The comparison must be carried out using criteria developed during the detailed design preceding the construction and will take place once the repository access reaches a particular milestone or checkpoint. If the comparison shows that the actual site conditions deviates outside the predicted variability, and that the consequence of such deviation is significant, the as-built conditions are reported to the SIP for review and possible mitigating measures, see Figure 3-2. Clearly the criteria for comparing the as-built conditions with the predicted conditions must be developed in detail and fully specified. In this example such criteria can only be specified once the expected ground conditions for the repository access excavations have been established. Hence investigations will be required before hand to establish the ground conditions in sufficient detail to establish the criteria.

In the given example the geohazard, i.e. groundwater inflow, can be predicted and it can be measured directly. However, in other situations the geohazard cannot be measured directly. For example, while in situ stress is recognized as a geohazard, the maximum horizontal stress is measured indirectly using either hydraulic fracturing, overcoring or convergence methods. In this example the criteria for comparing the as-built conditions encountered with the predictions, must also specify the methodology used to interpret the indirect measurement. Regardless of the measuring and monitoring requirements, procedures and guidelines must be developed with the understanding that a main purpose of the investigations and monitoring is to assess site conditions that were used as the basis for the detailed design and to quantify the deviations from those conditions should they occur.

3.3 Stepwise development of the underground facilities

The development of the underground facilities is carried out in stages. Initially the accesses to repository depth are developed, followed by the central area and the deposition tunnels and holes for the test operation. Finally, during the routine operation, the repository will be developed in stages. During each stage deposition works and rock construction works are carried out in parallel on opposite sides of a partition wall, see **Repository production report**, Section 4.1.4. Each stage comprises the construction of deposition tunnels and holes required for a given number of canisters. During each development stage deposition works are carried out in the part of the deposition area completed in the previous stage, and detailed site investigations are performed for the deposition tunnels and holes to be constructed in the next stage. Thus there are three separate activities associated with a stage in the development of deposition areas:

1. investigation of the detailed site conditions and the adapting of the layout to those conditions,
2. construction of deposition tunnels and deposition holes, and
3. deposition works including deposition of canisters and installation of buffer, backfill and plug at the end of deposition tunnels.

The step-wise development of the deposition areas will enable systematic auditing of the design and construction activities.

3.4 Control programme

The control programme shall ensure, using standard quality control and assurance procedures, that the construction works and constructions methods conform to the reference methods. The main objective of the control programme is to secure that the reference methods perform in such a way that the design premises, quality and efficiency are fulfilled.

With respect to long-term safety the control programme embraces, but is not limited to:

- inspection of delivered material in terms of quantity and quality,
- control and inspection of construction works e.g. grouting and excavation activities,
- inspection of the results of the construction works e.g. inflow, geometry and excavation damage zone.

The control programme and its quality documentation constitute the basis for the evaluation if the performance of the reference methods has been acceptable with respect to long-term safety. The quality documentation comprises, but not limited to:

- documentation of the performance of material and reference methods,
- documentation of quality related to the design premises, and any non-conformity and related correcting measures,
- as-built drawings containing positions and geometry and material.

The overall requirements and objectives of the control programme will be defined before the start of the construction. Experiences will be obtained successively during the excavation of the repository, which may result in modification to the reference methods in order to meet the design premises.

3.5 Documentation of as-built/initial-state conditions

As illustrated in Figure 3-2 the formal documentation of the in situ conditions and the layout adopted for those conditions are provided in an as-built documentation. The formal requirements for the content of the as-built documentation will be developed in conjunction with the requirements for the test operation. The documentation will provide information for the initial state of the deposition tunnels and holes completed during a development stage and include the following tentative contents.

1. The spatial location of the boundaries of the deposition area.
2. The spatial location of investigation boreholes.
3. The spatial location of the deposition tunnels.
4. The spatial location of the accepted and rejected deposition holes.
5. Documentation of inspections and inspection-results that demonstrate conformity to the design premises.
6. Documentation of any non-conformity related to long-term safety and related mitigative measures.
7. Documentation of all engineered materials left in the rock mass.

In parallel to the development of the main tunnels, deposition tunnels and holes the rock mass conditions are documented as part of the development of the SDM for the deposition area.

4 The reference design at Forsmark and its conformity to the design premises

This chapter presents the reference design of the underground part of the KBS-3 repository facility located in Forsmark and the conformity of the underground openings to the design premises stated in Section 2.3. The reference design is the result of the completed Design step D2. The results from Design step D2 have been reported in several individual design reports. The most significant results and SKB's conclusions from Design step D2 are presented in /SKB 2009b/, which is the main reference for this chapter.

The reference design reflects the current level of detail and the current status of rock engineering for the underground facilities at Forsmark. The underlying design methodology and the engineering tasks that have been undertaken to establish the reference design in Design step D2 are described in /SKB 2007/. The conceptual layout and nominal dimensions of the underground openings are given in /SKB 2007/. Additional design premises for the dimensions of the underground openings imposed by the engineered barriers and plug are presented in Section 2.3.2.

The reference design represents one possible layout of the underground facilities at Forsmark. It also comprises an estimation of material quantities for rock support and grouting. The site-specific basis for the reference design is geotechnical information, which has been interpreted and evaluated in a SER (site engineering report) /SKB 2009c/. The information presented in /SKB 2009c/ builds on the extensive surface-based site investigations carried out at the Forsmark site and presented in the SDM (site descriptive model) /SKB 2008/. It is important to point out that the verification of the conformity of the reference design to the design premises stated in Section 2.3 is restricted by the currently anticipated uncertainties related to the SDM and SER. The reference design established in Design step D2 will be the basis for the next design step. The successive excavation of underground openings will provide information that reduces uncertainties with regard to the SDM and SER, and the reference design will gradually be developed in accordance with the overall design methodology presented in Chapter 3.

In Section 2.3 the design premises for the underground openings are divided into design premises:

- related to the functions in the KBS-3 repository,
- from the engineered barriers and plug,
- related to the production and operation.

In the following sections the reference design and its conformity to these design premises are presented. The design premises related to the functions in the final repository are presented under the subtitles:

- repository depth,
- deposition areas,
- deposition holes,
- deposition tunnels,
- other underground openings,
- engineered and residual materials.

Issues related to design premises from engineered barriers and production and operation are also included in the above subtitles.

The EDZ (excavation damaged zone), dimensions and tolerances of underground openings as well as grouting, are further discussed in Chapter 5 Reference methods.

4.1 Repository depth

The following design premises are stated for the repository depth and deposition areas in **Design premises long-term safety**.

- *The repository volumes and depth need to be selected where it is possible to find large volumes of rock fulfilling the specific requirements on deposition holes.*
- *With respect to potential freezing of buffer and backfill, surface erosion and inadvertent human intrusion, the depth should be considerable. Analyses in the SR-Can assessments corroborate that this is achieved by prescribing the minimum depth to be as specified for a KBS-3 repository, i.e. at least 400 m.*
- *With respect to hydrogeochemical conditions the following is stated:*
 - *reducing conditions; salinity – TDS limited; ionic strength – $[M^{2+}] > 1 \text{ mM}$; concentrations of K, HS^- , Fe – limited; pH – $pH < 11$; avoid chloride corrosion – $pH > 4$ or $[Cl^-] < 3 \text{ M}$.*

The reference depth was established considering these design premises and the constructability of the deposition tunnels and deposition holes. The main influence of the design premises stated in **Design premises long-term safety** on the reference depth is the hydrogeology of the site, i.e. frequency and occurrence of transmissive fractures and its correlation to depth, while the influence on depth from constructability is mainly related to rock mechanical issues, e.g. the likelihood and extent of spalling in deposition holes prior to emplacement.

A rationale for identifying suitable rock volumes for deposition as well as depth intervals for the final repository facility has been outlined in /SKB 2009c/. This rationale has been used to establish a depth interval where it is possible to find rock volumes that conform to the specific design premises for deposition holes and deposition tunnels with regard to:

- in situ temperature,
- fracture frequency,
- hydrogeology considerations,
- spalling considerations,
- available space – site adaptation,
- construction costs and environmental impact,
- other considerations.

Applying the above rationale resulted in a depth range of 450 m to 500 m according to SER /SKB 2009c/. The in situ stress magnitude and the fracture frequency of gently dipping water-bearing fractures were the governing conditions. The reference repository depth i.e. the depth from the 0-level to the roof of the highest located deposition tunnel is elevation –457 metres. The maximum depth of the tunnels in reference design is elevation –470 metres, i.e. where the transport tunnels (tunnel floor) exit from the central area. The minimum and maximum depths are based on the tunnel inclinations required for the drainage system.

4.2 Deposition area – placement of deposition holes

4.2.1 Thermal conditions

The layout of the deposition holes shall conform to the following design premise for thermal conditions stated in **Design premises long-term safety**.

- *The buffer geometry (e.g. void spaces), water content and distances between deposition holes should be selected such that the temperature in the buffer is $< 100^\circ\text{C}$.*

The thermal dimensioning methodology presented in /Hökmark et al. 2009/ was applied to determine the distance between deposition holes. The premises for the thermal dimensioning were: minimum distance between deposition holes 6 m, fixed canister spacing, maximum thermal power in the canisters 1,700 W and fixed deposition tunnel spacing 40 m. The calculated increase in temperature from the rock wall at mid-height of the canister to the buffer at top of the canister, where the highest temperature

in the buffer occurs, is presented in the **Buffer production line**, Section 4.4. Based on this the minimum spacing between deposition holes in the different rock domains was evaluated in /SKB 2009c/. The reference design conforms to the design premise provided that the minimum centre-to-centre spacing is 6.0 m in rock domain RFM029 and 6.8 m in rock domain RFM045.

Placing a deposition hole in rock with a very low thermal conductivity is not permitted. According to current knowledge, volumes of rock with a very low thermal conductivity, i.e. amphibolite, are sparse as well as detectable. The reference spacing between deposition holes does not take into account the fact that placing of deposition holes in rock with low thermal conductivity will be avoided, resulting in loss of canister positions. However, it is recognised that there is good potential for refining the design and reducing the canister spacing once underground data becomes available.

4.2.2 Mechanical conditions

The following design premises for the mechanical conditions in deposition holes are stated in **Design premises long-term safety**.

- *Deposition holes are not allowed to be placed closer than 100 m to deformation zones with a trace length longer than 3 km.*
- *Deposition holes should, as far as reasonably possible, be selected such that they do not have potential for shear larger than the canister can withstand. To achieve this, the EFPC criterion should be applied in selecting deposition hole positions.*

These design premises together with predetermined boundaries of the repository area governs the gross capacity of the final repository. A methodology for verifying the conformity of the reference design to these design premises have been established by SKB /Munier 2006, 2007, 2010/.

Firstly, deposition areas must not be located within 100 m perpendicular distance from the boundaries of modelled deformation zones with a 3 km trace length or equivalent size. Within the rock volume that will host the final repository, i.e. fracture domains FFM01 and FFM06, there are only four deformation zones that are large enough to potentially require a respect distance. These are the three steeply dipping zones ZFMENE060A, ZFMENE062 and ZFMWNW0123, and the gently dipping zone ZFMA2, see Figure 4-1. The reference layout was, in accordance with instructions given in /SKB 2009c/, fitted to a 3D model of deformation zones requiring respect distance.

Secondly, in order to mitigate the impact of potential future earthquakes, deposition hole positions are selected such that they do not intersect discriminating fractures. Deposition positions must satisfy the *Extended Full Perimeter Intersection* (EFPC) criterion /Munier 2010/. Theoretically, fractures with radii larger than about 60 to 200 m should be avoided, depending on the distance to the zone needing respect distance, but since fracture sizes may be very hard to measure more robust criteria are needed. For this purpose the EFPC criterion formulated in the following way is applied.

- Fractures that intersect the full perimeter of the tunnel, and that also intersect the canister location in the deposition hole are regarded potentially critical and all affected positions are rejected, see Figure 4-2 a.
- Additionally, to capture large fractures that do not intersect the full perimeter of the tunnel, any fracture intersecting five or more deposition holes is regarded potentially critical and all affected positions are rejected, see Figure 4-2 b.

There is uncertainty concerning the ability to predict the discriminating fractures at repository level based on surface mapping and core logging. As a result, the reference design layout was developed with the aim of maximising the number of potential deposition positions, taking all design premises and other constraints into consideration. The reference design has a gross capacity of 7,818 deposition hole positions and provides for a loss of deposition hole positions of approximately 23%. The reference design acknowledges the fact that loss of deposition positions is an uncertainty but judges that the actual loss of positions is much smaller. Prospects are good in finding more efficient means of identifying discriminating fractures. Furthermore, the number of potential deposition positions can be increased, for example by thermal optimisation or by utilising other potentially suitable rock volumes.

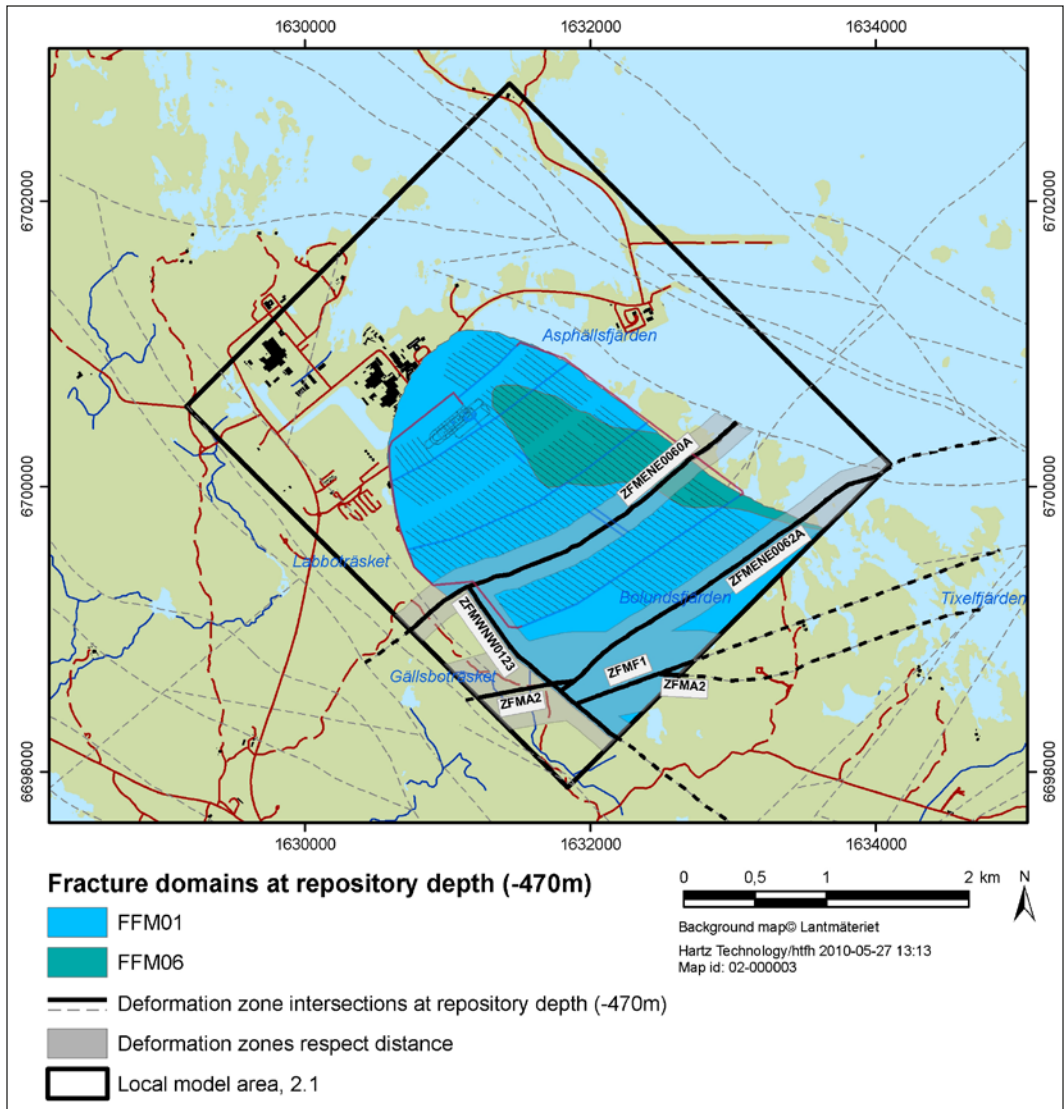

Figure 4-1. Deformation zones with respect distances which impact the repository layout. Section at repository depth (-470 m)¹.

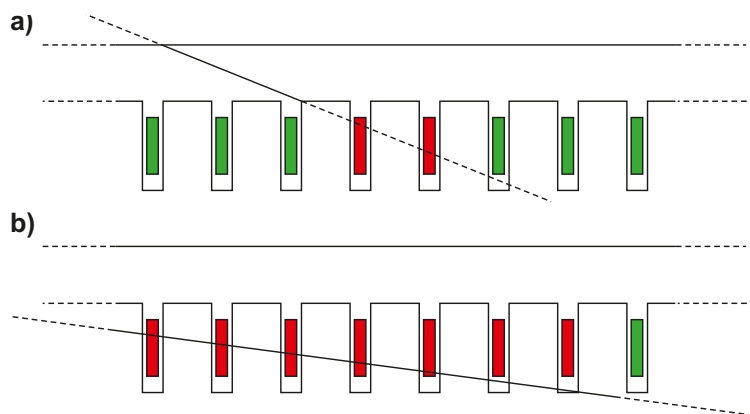

Figure 4-2. Illustration of a) the FPC criterion (Full Perimeter Intersection criterion) and b) the EFPC criterion (Extended Full Perimeter Intersection criterion). Red positions are rejected, green positions are accepted.

¹ Modelldatabasen, 2007. Model: DZ_PFM_REG_v22.rvs. Version 0.3. Approved 2007-08-31, Modified 2007-11-29. Modeller: A. Simeonov. Simon ID: GEO_IZTKKYIL, Svensk Kärnbränslehantering AB.

4.2.3 Hydrogeological conditions

The following design premises for the hydrological conditions in deposition holes are stated in **Design premises long-term safety**.

- *The total volume of water flowing into a deposition hole, for the time between when the buffer is exposed to inflowing water and saturation, should be limited to ensure that no more than 100 kg of the initially deposited buffer material is lost due to piping/erosion. This implies, according to present knowledge, that this total volume of water flowing into an accepted deposition hole must be less than 150 m³.*
- *Fractures intersecting the deposition holes should have sufficiently low connected transmissivity (specific value cannot be given at this point). This condition is assumed to be fulfilled if the conditions regarding inflow to deposition holes are fulfilled.*

A rationale for dealing with the situation of rejection of planned deposition hole positions due to unacceptable inflow was established in /SKB 2009c/. To summarise, most of these positions are likely to be screened out by the EFPC criterion, and the most likely situation is that very few additional deposition holes will be lost due to high inflow. Note that the EFPC criterion according to /Munier 2006/ was applied for this purpose, i.e. deposition positions were rejected if they were intersected by water conducting fractures also intersecting the full perimeter of the deposition tunnel independently of whether the canister location or any other part of the deposition hole was intersected. In the most extreme case, an additional 6% could be lost due to high inflows /SKB 2009c, Table 2-13/.

4.3 Deposition holes

The following design premise for the excavated damaged zone in deposition holes is stated in **Design premises long-term safety**.

- *Before canister emplacement, the connected effective transmissivity integrated along the full length of the deposition hole wall and as averaged around the hole, must be less than 10⁻¹⁰ m²/s.*

Damages related to the excavation resulting in increased transmissivity along deposition holes can be either the result of the applied method to excavate the holes, or a process governed by the mechanical properties of the rock and the redistribution of stresses around the excavated deposition hole. The EDZ induced by the excavation activities is related to the performance and execution of the reference method, and is discussed in Section 5.3.1.

The likelihood of spalling in deposition holes could be significantly reduced – if not eliminated – by aligning the deposition tunnels parallel to the maximum horizontal stress /Martin 2005/. A complete description of spalling and the methodology used to assess the spalling potential can be found in /SKB 2009b, Appendix B/. According to the guideline given in /SKB 2009c/, the deposition tunnels shall be aligned within ±30 degrees of the trend of the maximum horizontal stress to significantly reduce the risk of spalling in deposition holes.

For deposition holes, the three dimensional elastic analyses showed that aligning the deposition tunnels parallel to the maximum horizontal stress significantly reduces the maximum tangential stress on the boundary of the deposition hole. Moreover, the analyses indicated that such an alignment eliminates the concentration in tangential stress near the top of the deposition hole and provides a more uniform distribution of tangential stress along the deposition hole. For the “Most likely” stress model and for deposition tunnels aligned greater than 30 degrees to the maximum horizontal stress, tangential stress concentrations higher than current estimate of the spalling strength occurs in deposition holes. In such a case spalling occurs above the top of the canister.

With respect to the acceptable dimensions specified in Figure 2-1, a 5 cm overbreak relative to the nominal diameter of deposition holes is acceptable from the buffer block on top of the canister to the bottom of the deposition hole, i.e. from a depth of about 2 m below the deposition tunnel floor. (5 cm = acceptable radius 92.5 cm minus nominal radius 87.5 cm.) Additionally, in the part of the deposition hole where buffer is going to be deposited, the area of each horizontal cross section must not exceed the nominal cross section by more than 7.0%. The depth of spalling in deposition holes was

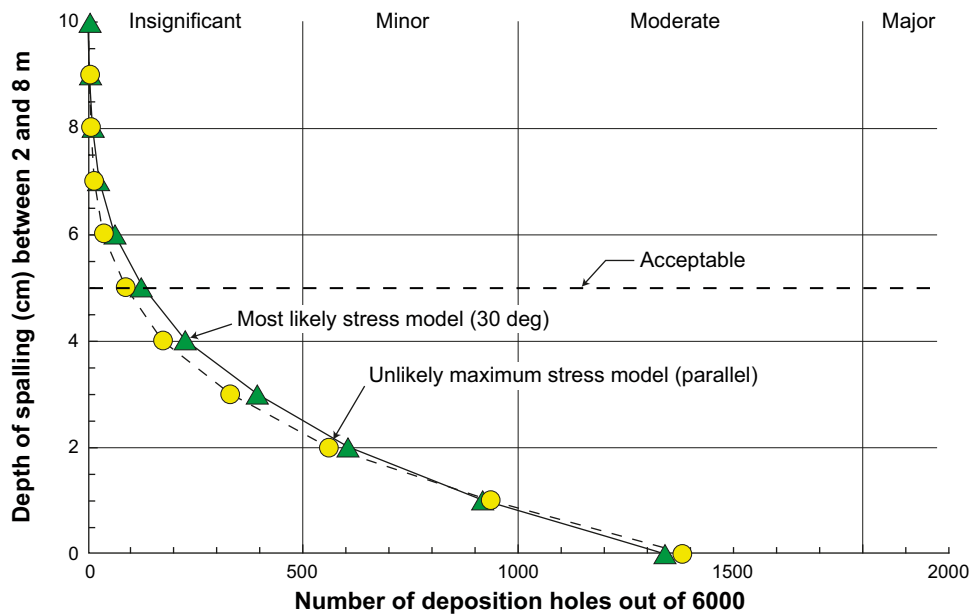

Figure 4-3. Loss of **deposition** holes for the “Most likely” stress model with the deposition tunnels at 30 degrees to the maximum horizontal stress and the “Unlikely maximum” stress model with the deposition tunnel parallel to the maximum horizontal stress /SKB 2009b/.

analysed in /SKB 2009b/, see Figure 4-3. In the case of the “Most likely” stress model, the results indicate that some 100–200 deposition holes (out of 6,000) would sustain a spalling depth (over-break) that exceeds 5 cm, provided that the deposition tunnels are aligned between 0 and 30 degrees to the maximum horizontal stress. For the “Unlikely maximum” stress model, the deposition tunnel must be aligned parallel to the maximum horizontal stress, but the number of deposition holes that can sustain a spalling depth in excess of 5 cm is approximately the same.

Spalling in deposition holes due to excavation-induced stresses is permitted, but the final deposition hole geometry must conform to the tolerances specified in the design premises imposed by the buffer. Uncertainties related to the in situ stress conditions, rock properties and the capability to model the extent of spalling and related changes in transmissivity, restrict a verification of the reference design at this stage. Means of reducing the remaining uncertainties related to spalling must be developed in the next design, something which is facilitated by the design methodology presented in Chapter 3. The contingency measure for reducing or eliminating spalling in deposition holes is to align the deposition tunnels parallel to the maximum horizontal stress. In the event that spalling occurs on the boundary of deposition holes, mitigation measures would need to be taken in order to increase the likelihood of achieving conformity to the above design premises. Loose rock debris from localised spalling on rock walls in deposition holes would be scaled off. Scaling or rock fall-out will affect the dimensions of deposition holes. Possible ways to adapt the installation of the buffer to the resulting geometry are discussed in the **Buffer production report**, Section 4.7.2.

The design premises imposed for the deposition holes by the buffer are given in Table 2-2 and the resulting nominal geometry and acceptable variations are illustrated in Figure 2-1. The depositions holes must conform to these design premises to achieve the required buffer density and a reliable installation of the buffer, see **Buffer production report**, Section 2.4.1. The specified acceptable deviations in radii include all possible causes e.g. alignment, straightness, displacements and rock fall out. This is discussed in Section 5.3.2.

4.4 Deposition tunnels

The following design premises for the excavated damaged zone in deposition tunnels are stated in **Design premises long-term safety**.

- *Excavation-induced damage should be limited and not result in a connected effective transmissivity, along a significant part (i.e. at least 20–30 m) of the disposal tunnel and, averaged across the tunnel floor, higher than $10^{-8} \text{ m}^2/\text{s}$.*

The most likely orientation of the maximum horizontal stress is Azimuth 145 degrees. The variability is assessed to be ± 15 degrees. Around 90% of the deposition tunnels in the reference design layout have orientation Azimuth 123–127 degrees and the remaining tunnels are aligned in approximately Azimuth 140 degrees. The orientations of the deposition tunnels in the reference design conform to the guideline given in /SKB 2009c/, stating that the deposition tunnels shall be aligned within ± 30 degrees of the trend of the maximum horizontal stress. A three dimensional elastic stress analyses confirms this guideline /SKB 2009b/. The results indicate that the stress concentrations in deposition tunnels aligned between 0 degree and 30 degrees relative to the orientation of the maximum horizontal stress are below the spalling strength used for the reference design. The results also suggest that stress concentrations in main tunnels as well as in their crossings with deposition tunnels are below the currently assumed spalling strength.

It is stipulated in /SKB 2009c/ that the final decision on the alignment of deposition tunnels shall take into account whether a prominent sub-vertical fracture set is aligned with the maximum horizontal stress. When the strike of a fracture set forms a narrow angle with a deposition tunnel, structurally related overbreak may occur and reduce the potential for maintaining an acceptable excavation contour. Thus, a balance must be sought between the likelihood of spalling and the potential for intersecting these sub-vertical fractures.

The design premises for acceptable dimensions and geometry imposed on the deposition tunnels by the backfill are given in Table 2-3. The acceptable dimensions and geometry of the deposition tunnels are illustrated in Figure 2-2. The deposition tunnels must conform to these design premises to achieve the specified backfill geometrical configuration and related installed density and to achieve a reliable installation. The EDZ induced by the excavation activities is related to the performance and execution of the corresponding reference method. This is discussed in Section 5.2.1.

The design premises imposed for the deposition tunnels by the plug are given in Table 2-4. They comprise the construction of a recess for foundation of the concrete plug and anchoring of structures for the installations, as well as acceptable inflow and strength of the rock mass in the area where the plug shall be installed. The construction of the recess is discussed in Section 5.2.5. For the other design premises imposed by the plug there are no specifications so far. For rock reinforcement and grouting the approaches discussed in Section 4.6.1 and 4.6.2 are applied.

4.5 Other underground openings

The following design premises for the excavated damaged zone in the underground openings in the central area, ramp, shafts and tunnels other than deposition tunnels are stated in **Design premises long-term safety**.

- *Below the location of the top sealing, the integrated effective connected hydraulic conductivity of the backfill in tunnels, ramp and shafts, and the EDZ surrounding them, must be less than 10^{-8} m/s . This value need not be upheld in sections where e.g. the tunnel or ramp passes highly transmissive zones. There is no restriction on the hydraulic conductivity in the central area.*

The occurrence of spalling in the access ramp and the transport tunnels were not analysed separately. However, the consequence of spalling from a long-term safety point of view is insignificant. Below the top seal the orientation and shape of the ramp can be modified to mitigate spalling, if necessary. Elastic stress analyses for the rock caverns in the central area was carried out using a 2D-modell /SKB 2009b/. The results suggest that when the central area is oriented between 0 degrees and 30 degrees relative to the orientation of the maximum horizontal stress, stress concentrations in the caverns are below the spalling strength for the reference design.

The EDZ induced by the excavation activities is related to the performance and execution of the corresponding reference method. This is discussed in Chapter 5.

4.6 Engineered and residual materials

The following design premises for engineered and residual materials left in the final repository, when the installation of buffer is performed or the underground openings are backfilled or closed, are stated in **Design premises long-term safety**.

For deposition tunnels:

- *only low pH materials ($pH < 11$),*
- *no continuous shotcrete.*

For boreholes, shafts and ramp, rock caverns and tunnels other than deposition tunnels:

- *only low pH (< 11) materials are allowed below the level of the top seal.*

Engineered materials left in the final repository consist of materials for grouting sealing and rock reinforcement. Cement is used in shotcrete, for embedding various support elements and in grout mixes for sealing purposes. In addition, there are residual materials from the operation of the final repository facility that will remain after decommissioning and preparations for installation of buffer, backfill or closure. For these the following design premise is stated in **Design premises long-term safety**.

- *Other residual materials must be limited – but the amounts considered in SR-Can is of no consequence.*

The assessed amounts of engineered materials from rock support and grouting activities and the amounts of residual materials are presented in Section 4.6.3.

In addition to the material the following applies to sealing of deposition tunnels:

- *continuous grouting boreholes outside tunnel perimeter should be avoided.*

General engineering guidelines /SKB 2009c/ were considered in the reference design with regard to rock support issues and sealing. These guidelines cover feasibility for both construction and deposition, and are highlighted below.

- The deposition holes shall be located in massive or sparsely fractured rock.
- The central area can be located in any rock mass suitable for constructing large caverns.
- The repository facility layout should minimise stress concentrations on the perimeter of the underground excavations (deposition holes and deposition tunnels), unless it can be shown that such stress concentrations do not cause spalling.

A rationale for identifying suitable rock volumes on the basis of the above guidelines was outlined in /SKB 2009c/. The underground openings in the reference design and their response to excavation have been characterised in accordance with the following principles.

An engineering description of the rock mass was established based on the site description, /SKB 2008/. This engineering description considers the rock domains, fracture domains, major deformation zones, ground water conditions and in situ stress conditions. It also incorporates parameters that are required to provide an engineering description of the rock mass. The product of this description is an identification of a number of ground types and of site-specific conditions that have been evaluated in the reference design. Three different ground types were defined based on the current knowledge of the geological setting.

Ground types are the basis for evaluating the rock mass behaviour of each underground opening after excavation without considering the effect of rock support or sealing. The ground behaviour also considers the influencing factors such as the relative orientation of relevant discontinuities to the excavation, ground water conditions and in situ stresses.

4.6.1 Rock support in underground openings

To facilitate estimates of quantities of ground support for the reference design, guidelines are given in /SKB 2009c/. They are based on extensive underground construction experience and outline which categories of rock support, e.g. rock bolts and shotcrete that may be suitable to use in the foreseen ground types. These categories are designated support types.

The rock caverns in the central area and transport tunnels connecting deposition areas to each other are not aligned parallel to the NE trending fracture set, which may be unfavourable from a rock mechanics point of view. This orientation will reduce the need for bolting as well as the likelihood of structurally-related overbreak. The results from the stress analyses for the central area /SKB 2009b/, indicate that the central area is located in a rock volume suitable for construction of large caverns.

The ramp will have tunnel sections which are aligned parallel to the NE trending fracture set. On the repository level, the main tunnels will also be parallel to the NE trending fracture set. The reference design includes quantities of rock support specifically aimed at reducing structurally-related overbreak to an acceptable level.

Using the “Most likely” stress model /SKB 2009b/ the in situ stress conditions at the depth of the repository are not expected to be sufficient to cause stress-induced stability problems – spalling – in the underground openings. However, there is uncertainty regarding this design parameter. In order to prevent minor spalling from being an occupational safety issue, roof support with shotcrete is included in the reference design for all underground openings except in the deposition tunnels where wire mesh shall be used if necessary.

4.6.2 Grouting measures in underground openings

The design premises for acceptable inflow imposed on the deposition tunnels by the backfill are given in Table 2-3. The deposition tunnels must conform to these design premises to achieve a reliable installation of the backfill.

In order to limit the water inflows as much as possible, the following general engineering principles were considered in the reference design /SKB 2009c/.

- The access tunnels (ramp) and shafts should be located to minimise the potential for large groundwater inflows.
- The layout for the ramp and shafts should be oriented so that the intersection lengths with major water bearing zones are as short as possible.

The reference design also contains an assessment of the extent to which grouting must be used to conform to the specified acceptable inflows. In the specifications used to establish the reference design, grouting of the rock surrounding the underground openings at repository level were limited to using cement-based grout ahead of the advancing excavation /SKB 2007/, i.e. pre-grouting. Available results indicate that the sealing efficiency of cement-based grouting at the repository level will be sufficient and that the reference design conforms to the specified inflow. However, for certain fractures and deformation zones in deposition tunnels it may not be practical to use cement-based grouts. While there is acceptable confidence that the number of occurrences for such conditions is relatively few, there is uncertainty regarding the level of effort for controlling the groundwater inflows under such circumstances. In order to reduce this uncertainty, options were included in the reference design for the use of solution grouting, e.g. such a method tested at the Äspö Hard Rock Laboratory (HRL) /Funehag 2008/, see Section 5.2.4.

In fracture domain FFM02, located within the upper 100–200 m of the rock, the rock has a relatively high frequency of transmissive fractures. Extensive grouting measures may be needed for the access excavations that penetrate this fracture domain. The reference design acknowledges that detailed grouting plans can only be prepared once the detailed site specific information is obtained.

In fracture domains FFM01 and FFM06, the frequency of transmissive fractures is generally low and decreases with depth. The grouting of different underground openings below a depth of 200 m can be carried out as selective pre-grouting, with probe hole investigations, when passing deformation zones and where discrete water-bearing fractures are encountered.

Below a depth of approximately 400 m, the observed frequency of flowing features is very low and grouting of flowing fractures and zones will be localised and not result in continuous grouting holes outside the deposition tunnel perimeter. The cumulative density function of transmissivity values in 20 m long sections indicates that on average, less than 2% of the 20 m sections between deformation zones will require grouting /SKB 2009c, Section 2.5/ and that each deposition tunnel will on average intersect two deformation zones that will require pre-grouting.

Decisions to grout will be based on probing inside the tunnel perimeter. However, construction experience indicates that detecting these fractures by means of traditional probe hole drilling from the tunnel face may be difficult, particularly if the water-bearing fractures have relatively small apertures with channelised flow. Due to the difficulty in identifying individual water-bearing fractures, any point leakages of >0.1 l/min remaining in deposition tunnels will be sealed by post-grouting.

The design premises do not restrict the use of grouting around deposition holes. However, grouting was not considered in the reference design as a means of reducing inflow in potential deposition holes. The bottom holes of grouting fans in deposition tunnels will be drilled inside the tunnel contour to prevent grouting holes from intersecting potential deposition hole positions. The grouting fans located in deformation zones will not be constrained since deposition holes are not allowed in deformation zones.

The ventilation shafts in the deposition area that connect to the ground surface will be constructed using raise-boring techniques. Grouting in these shafts will be carried out before excavation (raise drilling) begins, if required. This grouting would require long boreholes with minimum deviation. Boreholes could be drilled from the surface and from underground.

4.6.3 Quantities of engineered and residual materials

Engineered materials originating from rock support and grouting activities will remain in the final repository after decommissioning and closure of the repository facility. Residual materials from the operation of the final repository facility will also remain in the final repository.

The structural elements included in the rock support are rock bolts, shotcrete, fibre reinforcement and wire mesh. It is assumed that shotcrete with its additives, aggregates and fibre reinforcement as well as wire mesh will remain on the rock surfaces of the underground openings and that rock bolts will remain in the rock walls and roofs of the underground openings. The bolts, fibre reinforcement and wire mesh mainly consist of iron. The assessed material quantities used for ground support left in the different kinds of underground openings are given in Table 4-1 /SKB 2009b/. Table 4-1 includes total masses and volumes as well as relative quantities expressed in kg/m³.

The assessed quantities from grouting activities are given in Table 4-2 for the different functional areas /SKB 2009b/. The estimated quantities concern cement, silica fume, silica sol and additives. The total number of grout holes and the corresponding drilled metres are also given.

The quantities of grout presented in Table 4-2 includes the grouting in probe holes, pre-grouting at the tunnel face, post-grouting and cut-off grout curtains for shafts and for the top part of the ramp located in fracture domain FFM02. The grouting methodology comprises three different cement-based grout mixes with a low pH. The average quantity of cement plus silica fume in 1 m³ of grout mix is 790 kg. The cement quantities used for plugging the grout holes after grouting is completed are not included in Table 4-2. This additional cement quantity has been estimated to 1,000 tonnes.

The assessed quantities of residual materials from the operation of the final repository facility are given in Table 4-3 for the different underground openings /Lindgren et al. 2009/. The inventory of residual materials concerns normal operation and does not include e.g. accidents, fire or sabotage.

The assessed quantities are based on the assumption that the underground openings are decommissioned and cleaned so that 1% of the materials brought into the repository for the operation will remain in the repository. The largest amounts of residual materials are steel and rust from rock bolts securing ventilations equipment and cables, residuals from concrete constructions such as firewalls, pumping pits and roadways in the facility and nitrate salts from the explosives. The quantities of residual materials, other than the bottom plate, left in the deposition holes are very limited, even too small to be quantified.

The materials and their amounts given in Table 4-3 have been compared to the materials and amounts presented in the initial state report for SR-Can. No new materials are identified and the estimated amounts are comparable to those presented in SR-Can.

Table 4-1. Compilation of the material and quantities expected to be used for ground support in different parts of the repository /SKB 2009b, Table 6-6/.

Subsidiary material	kg/m ³	Ramp/access		Central area, including ventilation		Deposition area, including SA01 ² and SA02 ²	
		[ton]	[m ³]	[ton]	[m ³]	[ton]	[m ³]
Rock Bolts							
Rock bolts (l=3 m, d=25 mm)	4	27		52		182	
Wire mesh (1.7 kg/m ²)						96	
Fixing bolts (29,329 pcs)						28.2	
Rock Bolt Grout							
Cement	340	15	7	28	13	98	47
Silica	226.7	10	5	19	9	65	31
Water	266.6	12	12	22	22	77	77
Glennium 51	4	0.2	0.2	0.3	0.3	1	1
Quarts filler	1,324	57	29	109	54	381	191
Shotcrete							
Water	158	239	239	340	340	744	744
Ordinary Portland cement CEM I 42.5	210	318	151	452	215	989	471
Silica fume	140	212	101	301	143	659	314
Coarse aggregate (5–11)	552	836	492	1,187	698	2,600	1,529
Natural sand (0–5)	1,025	1,552	913	2,205	1,297	4,227	2,839
Quarts filler (0–0.25) or Limestone filler (0–0.5)	250	379	189	538	269	1,177	589
Superplasticiser "Glennium 51" from Degussa	3	4.5	4.5	6.5	6.5	14	14
Air entraining agent "Sika AER S"	2.5	3.8	3.8	5.4	5.4	12	12
Accelerator "Sigunit" from Sika or AF 2000 from Rescon	7% ¹	0.1	0.1	0.2	0.2	0.3	0.3

1) Tests performed have given values between 4 and 10%. An average value of 7% was however chosen for these calculations.

2) SA01 and SA02 are ventilation shafts in the peripheral parts of the deposition areas.

Table 4-2. Estimated quantities of grout materials and drilling that remain in the rock mass after excavation of the different underground openings (based on /SKB 2009b, Table 7-4/).

Element	Material	Ramp/Shafts (ton) ¹⁾²⁾		Central Area (ton) ¹⁾		Deposition Area (ton) ¹⁾	
		min	max	min	max	min	Max
Cement grouting	Water	350	1,360	3	10	110	440
	Portland ³⁾	330	1,310	3	8	100	400
	Silica Fume ⁴⁾	460	1,790	4	11	140	550
	Super Plasticiser ⁵⁾	23	90	0.2	0.5	7	30
Solution grouting	Silica Sol	105	410	3	9	160	640
	NaCl solution	21	85	0.6	2	30	130
Volume of grout (m ³)		910	3,580	10	30	405	1,620
Drilling	Number of holes	7,980 pcs		300 pcs		17,160 pcs	
	Drilling meter	205,000 m		6,000 m		343,000 m	

1) Based on "type" hydraulic conditions (K_{typ}).

2) Incl. the Exhaust shafts SA01 and SA02.

3) Sulphate resistant Ordinary Portland cement with d₉₅ on 16 µm, type Ultrafin 16 or equivalent.

4) Dispersed silica fume, microsilica with d₉₀=1 µm type Grout Aid or equivalent. The density is to be between 1,350–1,410 kg/m³ and 50% ±2% of the solution is to consist of solid particles, see Appendix C in /SKB 2009b/.

5) Super plasticiser, naphthalene-sulphonate based, density about 120 kg/m³, type SIKa Melcrete.

Table 4-3. Estimated quantities of residual materials (in addition to engineered materials given in Table 4-1 and Table 4-2) that remain in the rock underground openings at closure of the final repository /Lindgren et al. 2009/.

Material	Quantities of residual materials in the final repository (kg)					
	Deposition holes	Deposition tunnels	Main and transport tunnels	Central area	Ramp and shafts	
Detonators with leaders	Zinc	*	5	3	0.6	1
	Plastic	*	80	40	9	20
Explosives	NOx	*	7	4	1	2
	Nitrate salts	*	2,000	1,000	200	400
Bolts	Steel	*	50,000	40,000	10,000	20,000
	Concrete	0	0	30,000	8,000	20,000
Roadways	Concrete	0	0	2,000	600	1,000
	Asphalt**	0	0	0	0	500
Concrete constructions	Concrete	*	3,000	2,000	600	1,000
Tyre wear		*	1	5	1	3
Exhausts	NOx	*	7	30	9	20
	Particles	*	0	0	0	0
Detergents and degreasing compounds		0	0	0	*	0
Hydraulic and lubrication oil		*	200	50	10	20
Diesel oil		*	*	*	*	*
Battery acid		*	*	*	*	*
Metal chips and hard metal		*	5	1	0.3	1
Wood chips	Wood	*	10	0.6	0.2	0.3
Corrosion product	Rust	*	4,000	200	50	90
Urine	Urea	*	6	1	0	0.6
Other human waste	Organics	*	60	10	3	6
Ventilation air	Organics	*	10	5	1	2

* too small to quantify

** in the ramp but not in the shafts

5 Reference methods

5.1 General basis

The design premises in **Design premises long-term safety** and the design premises imposed by the buffer and backfill together with the design considerations presented in Section 2.2.2 result in design premises for a number of methods used for the construction of the underground openings. This chapter presents the reference methods for the construction. SKB regards the reference methods as technically feasible, however, some methods need to be further developed before the construction of the repository facility commences.

The used technology, the operational aspects and the environment in which the reference methods are operated, are all possible sources of uncertainty relative to the performance of the reference methods. The conformity to the design premises will be handled as part of the observational method and the development of quality control and assurance procedures as outlined in Section 3.4. A general description of methods and approach to monitor the performance of the reference methods is given in /SKB 2010/.

Within the framework of the observational method the predicted performance of the reference methods need to be fully established before they are put in operation to construct the underground openings of the repository facility. Moreover, before a reference method can be considered as operational, parameters and criteria (threshold levels) that shall be used to predict the performance must be established. Observable and quantifiable parameters with potential for predicting the performance of the reference methods are outlined in the following sections.

5.2 Reference methods used for the construction of deposition tunnels

The reference method for excavating the deposition tunnels is drill and smooth-blasting techniques. The design premises for the deposition tunnels related to their function in the KBS-3 repository are given in Table 2-1 and the design premises imposed by the backfill are given in Table 2-3. Prior to the installation of the backfill the conformity of the connected transmissivity, the amount and composition of engineered and residual materials in the tunnel, the inflow and geometry to the design premises shall be verified, and the tunnel shall be prepared for installation of the backfill, see Section 5.2.6 and the **Backfill production report**, Section 5.4.3.

5.2.1 The excavation damaged zone using drill and blast techniques

In **Design premises long-term safety** it is stipulated that the contribution from the EDZ to the connected effective transmissivity along and across deposition tunnels shall be limited. The appearance of an EDZ is typical in underground openings excavated by drill and blast. /Bäckblom 2008/ states that many studies correlate damage with the concentration of explosives used. Equally important are the accuracy and precision in drilling the blast holes, and using exact ignition times, e.g. by utilising electronic detonators /Ericsson et al. 2009/. In addition, local geological conditions and the rock stress environment will influence the resulting EDZ /Jonsson et al. 2009/.

Whether EDZ is continuous or discontinuous over adjacent blast rounds is of importance, because if the EDZ's are connected between rounds there is potential for an addition to the natural connected transmissivity. Based on experiences from the excavation of the TASQ tunnel at the Äspö HRL /Olsson et al. 2004/ it was noted in SR-Can that it is possible to design and control the drilling and blasting of tunnels such that continuous fracturing along the axial direction of the tunnel will not develop. This notion has been demonstrated at the Äspö HRL in the TASS tunnel using smooth-blasting techniques /Olsson et al. 2009, Ericsson et al. 2009/. Results from the TASS tunnel show that proper control of drilling and blasting procedures result in blast-induced fractures that are dominantly radial in direction and that such fractures are not continuous over any significant distance along the axial direction of the tunnel.

A reasonable value for the hydraulic conductivity of the damage zone is in the order of 10^{-8} m/s. This magnitude has been obtained during several tests in crystalline rocks, where the excavation was of good quality and measured by integrating measurement under saturated conditions along the tunnel floor /Bäckblom 2008/. Point observations of the hydraulic conductivity have provided both lower and higher individual results. This is due to the natural variability of the rock properties as well as to the fact that damage is correlated to the amount of explosives. The latter varies along the periphery of the opening and also along the longitudinal section of the tunnel.

The properties of a damaged zone surrounding an underground opening change if spalling has occurred. The results of the major experiments suggest that the hydraulic conductivity of such a zone will be in the order of 10^6 m/s and that it extends a couple of decimetres into the rock surrounding the underground opening /Bäckblom 2008/.

The parameters that have potential to predict and verify the performance of the reference method and for which criteria will be determined are the amount of explosives close to the periphery, accuracy and precision in drilling the blast holes, distance between blast holes and accuracy and sequencing of the ignition. The reference method will include calibration procedures to accommodate the site specific conditions that deviate from the most probable conditions, e.g. by adjusting the drill pattern or by changing the type of detonators.

Monitoring and control programmes

SKB plans to develop several procedures for verifying that the EDZ conforms to the design premises. Primarily quality control and assurance procedures included in the control programme will be applied to control and inspect that the drilling, charging and ignition sequences are properly executed. The influence from rock conditions on EDZ will be evaluated within the framework of the observational method and the associated monitoring programme, i.e. combining results from geological characterisation, geophysical techniques and geological modelling.

The completed deposition tunnels are visually inspected to identify any occurrences of localised blast damage or spalling. The potential to conform to the design premises for connected effective transmissivity can be improved by removing loose rock debris on the rock walls. This mitigation measure requires that a criterion is established that define the accepted intensity of loose rock debris. The reference design includes mitigation measures to reduce the risk of spalling as the deposition tunnels are aligned sub-parallel to the major horizontal stress, see Section 4.3.

5.2.2 Geometrical tolerances

Acceptable geometrical tolerances for the deposition tunnels are imposed by the backfill, see Figure 2-2. The constraints concern the total volume of the excavated tunnel, the maximum cross-sectional area and cavities in the tunnel floor. Moreover, underbreak is not allowed, i.e. the rock contour may not protrude inside the nominal tunnel profile.

Smooth-blasting techniques were demonstrated at the Äspö HRL. The demonstration included seven excavation stages. The intermediate results from four stages, or 12 blasting rounds have been reported /Malmatorp et al. 2009/. The results showed that proper control of drilling and blasting resulted in conformance to the geometrical tolerances for maximum allowable cross-section and excavated volume. The rock surfaces in tunnels excavated by drill and blast are rough and it can not be excluded that small volumes of rock will protrude inside the nominal cross-section, i.e. underbreak.

The results of blasting rounds 6 to 12 have been used to estimate the installed backfill density at the initial state, see **Backfill production report**, Section 6.1.4. For this purpose the as-built volumes of the tunnel are compiled in Appendix A.

A look-out angle of 250 mm was found to provide sufficient space for the drilling equipment but did not eliminate all occurrences of underbreak. It is therefore reasonable to estimate the backfill density based on that drilling of the contour holes is made with a look-out angle of 250 mm. Based on the experimental data the average excavated volume per round was assessed to be approximately 18% larger than the nominal volume i.e. well within the acceptable limit of 30% larger than the nominal volume.

The parameters that have potential for predicting and verifying the performance of the reference method and for which criteria will be determined are related to control and inspections of the precision and accuracy in drilling of the blast holes. This applies in particular to the blast holes along the perimeter of the tunnel (contour holes) and to the nearest row of blast holes (stopping holes). Precision applies to positioning at the start and completing the drilling at the attempted end location. Accuracy applies to drilling parallel holes and achieving the attempted look-out angle of the drill holes. Moreover, means of detecting and removing underbreak will be an integral part of the reference method. The reference method will include calibration procedures to accommodate the rock conditions that deviate from the most probable conditions. For example an increasing tendency in occurrences of underbreak can be handled by adjusting the drill pattern.

Control programme

There are suitable methods and instruments for inspecting the geometry of deposition tunnels, e.g. laser scanning and geodetic methods. SKB will develop a procedure to inspect that the geometrical tolerances in deposition tunnels conform to the design premises. The control programme for drilling, charging and ignition that will be developed for EDZ is applicable. The geometrical tolerances after blasting will be inspected by one or a combination of the measurement methods mentioned above. In addition SKB will customise a modelling tool that can evaluate the relevant geometrical properties of the deposition tunnel.

Nonconformity to the specified maximum cross-sectional area and maximum volume is foreseen to be mitigated. Shotcrete will be applied locally where required, to smoothen out the rock surface due to any irregularity or rock fall out. Underbreak will be removed by using mechanical equipment. The final contingency action would be to disqualify the deposition tunnel in the event of nonconformities to the geometrical tolerances that cannot be mitigated. A deposition tunnel that has been disqualified will be backfilled in the same way as a main tunnel, see the **Closure production report**.

5.2.3 Tunnel floor contour

Acceptable geometrical tolerances for the deposition tunnel floor are imposed by the backfill. SKB will develop a reference method that can provide a tunnel floor contour that conforms to the design premises imposed by the backfill. A feasibility study of potential methods is ongoing in which smooth blasting techniques and wire sawing techniques, or combinations thereof, are assessed.

Control programme

The control programme that will be developed for geometrical tolerances is applicable, see Section 5.2.2.

5.2.4 Grouting techniques and grouting results

Acceptable inflow conditions for deposition tunnels are imposed by the backfill. The current reference method for sealing the rock surrounding the underground openings is grouting the rock beyond the excavation face, i.e. pre-grouting, using low pH cement /SKB 2007/.

Suitable grouting measures were assessed for the reference design /2009b/. This evaluation pointed to that grouting between deformation zones at the repository level will be very limited. When grouting is required, it is anticipated that cement based grouts will be adequate to achieve the required sealing efficiency. However, in some situations the transmissivity of a fracture could be so low that reaching the required sealing efficiency may not be practical with cement based grouts. In order to conform to the design premises the use of solution grouting may be required. The application of solution grouting under such conditions is considered to be new technology.

Intermediate results from testing solution grouting with silica sol at the Äspö HRL have been reported in /Funchag 2008/. The results from the demonstration showed that the expected sealing efficiency can be achieved when detailed design procedures /Fransson 2008/ are combined with proper control of the grouting operation. The detailed design included investigation boreholes and hydrogeological characterisation of the rock volume that was going to be grouted. The grouting operation included procedures for controlling grout pressures and rheological grout properties and verifying them relative to the criteria established in the detailed design.

SKB will continue the development of the reference method, i.e. the design methodology and the operational aspects. Parameters and criteria for predicting and verifying the performance of the reference method will be established for specific purposes. For example potential parameters that relates to the rock conditions and to the sealing efficiency are the distribution of fracture apertures, grout pressure in combination with rheological properties of grouts and consumed volume of grouts. The latter parameters can be quantified and implemented as stop criteria in the operations.

The final testing and means of calibrating the reference method will be undertaken in representative rock conditions and with grout material and grouting equipment that will be used in operations at the repository level.

Monitoring and control programmes

SKB will develop several procedures for verification of that the inflow in deposition tunnels conforms to the design premises. The input to detailed design will be obtained within the framework of the observational method and the associated monitoring programme, i.e. combining results from geo-hydrological characterisation and geological modelling in different scales. The model that refers to “tunnel” scale comprises geo-hydrological characterisation of at least one investigation hole drilled along the planned location of the deposition tunnel. A control programme will be applied to verify the performance of the grouting operation.

After completing the excavation it is relatively straightforward to inspect the inflow. Normally, measuring weirs are constructed across the tunnel floor to measure the inflow. Monitoring results have a high reliability in stationary conditions and can be used to determine inflows along the full length of the tunnel or between weirs. It is foreseen that the monitoring programme will be in place until the deposition activities commences.

If the inflows do not conform to the design premises, the contingency action will be post-grouting. Post-grouting will be carried out using cement grout or solution grouting. The ultimate contingency action would be to disqualify the deposition tunnel if the results from mitigation measures are inadequate.

5.2.5 Recess for the plug in deposition tunnels

The design premises for deposition tunnels imposed by the plug installed at the end of the tunnel after it has been backfilled are found in Table 2-4. The related rock engineering work includes the excavation of a recess for anchoring of the concrete plug, see Figure 5-1. The required recess and anchoring can be prepared by applying conventional technique.

5.2.6 Preparation of deposition tunnels

The preparation of the deposition tunnels is carried out before installation of buffer and deposition of canisters is initiated in the tunnel. The preparation of deposition tunnels comprises the following activities, see **Backfill production report**, Section 5.4.3.

- The rock walls of the tunnel are inspected and if necessary scaling and rock bolting are executed.
- Roof bolts that reach inside the nominal cross section of the tunnel are cut behind the washer.
- The tunnel is cleaned and emptied of equipment from earlier activities.
- The tunnel bottom is cleaned from gravel and other materials and inspected.
- The inflow to the tunnel is inspected.
- Scanning of the rock walls is carried out to determine the tunnel volume, the tunnel contour and the geometry of the bevels.
- Temporary ventilation, electric supplies and lighting are installed in the tunnel.

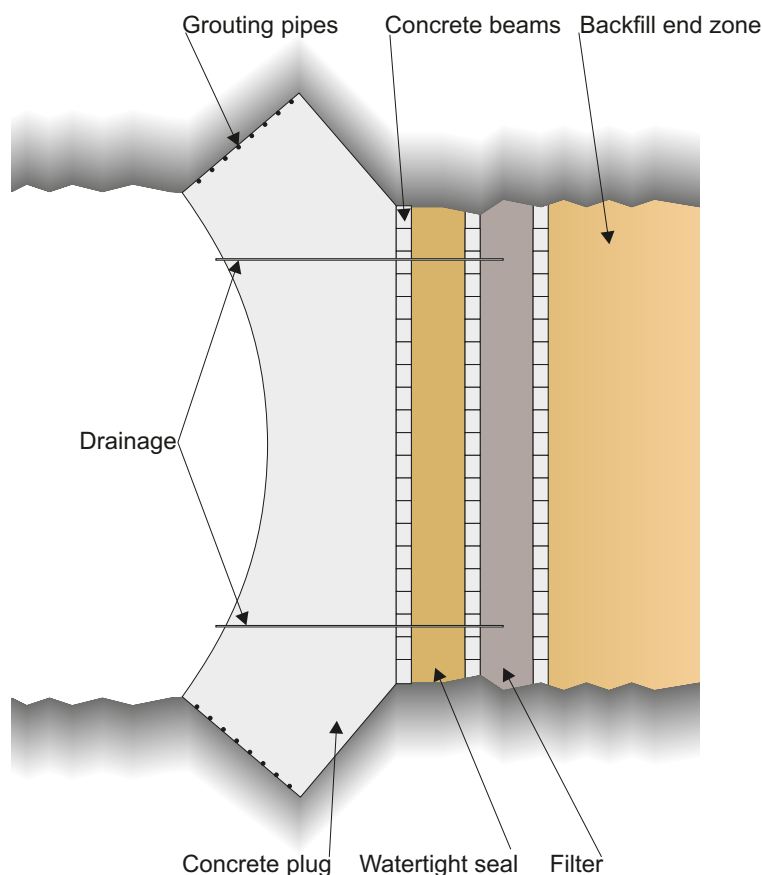

Figure 5-1. Schematic illustration of a reinforced plug that is anchored in a recess in the rock around the deposition tunnel.

5.3 Reference methods used in construction of deposition holes

The reference method for excavating the deposition holes are full-face down-hole drilling techniques. The design premises for deposition holes related to their function in the KBS-3 repository are found in Table 2-1 and the design premises imposed by the buffer are found in Table 2-2. Prior to the installation of the buffer the conformity of the fractures intersecting the deposition hole, the inflow, the connected transmissivity and geometrical tolerances to the design premises shall be verified and the deposition hole prepared for installation of the buffer, see **Buffer production line**, Section 5.4.3.

5.3.1 Excavation damaged zone using mechanical excavation techniques

In **Design premises long-term safety** it is stipulated that the contribution from EDZ to the connected effective transmissivity in deposition holes must be limited. In **Design premises long-term safety** it is foreseen that the deposition hole conforms to the design premises for connected effective transmissivity (less than 10^{-10} m²/s, see Table 2-1) if it conforms to the conditions for acceptable inflow. However, as discussed in Section 4.3 the reference design does not rule out the likelihood of local spalling due to local heterogeneities of the rock properties and the horizontal stress direction.

In underground openings excavated with mechanical excavation methods it is possible to achieve a EDZ that is limited to a few centimetres into the rock surrounding the excavation and with a hydraulic conductivity that is in the order of 10^{-10} m/s /Bäckblom 2008/. These properties are valid in rock conditions where spalling has not occurred. Hence the full-face down hole drilling method can be expected to create very little damage to the surrounding rock walls. The resulting connected effective transmissivity after excavation will therefore be governed by the connected transmissivity of natural fractures that intersect the deposition holes and the occurrence and intensity of spalling.

Control programme

Currently there is no reliable method that can quantify the connected effective transmissivity. Geophysical techniques have been used to characterise EDZ, however, none of these are by themselves sufficient for assessing the intensity and extent of the EDZ. Currently it is foreseen that the deposition holes conform to the design premise for the connected effective transmissivity if it conforms to the conditions for acceptable inflow. An inflow criterion will be established based on the design premise in **Design premises long-term safety** stipulating the maximum volume of water that is allowed to enter the deposition hole after the buffer is exposed to water until it is saturated.

A visual inspection of the completed deposition hole is necessary in order to rule out the occurrence of spalling. Should localised spalling occur, the potential to conform to the design premises for connected effective transmissivity can be improved by removing loose rock debris on the rock walls. This mitigation measure requires that a criterion that defines the accepted intensity of spalling is established. The final contingency action will be to reject and backfill the deposition hole.

5.3.2 Geometrical tolerances

Acceptable geometrical tolerances for deposition holes are imposed by the buffer. The design premises concerns the minimum diameter, minimum and maximum radius as well as maximum cross-sectional area. This will impose constraints on the performance of the reference method in terms of the resulting diameter and straightness of the deposition hole. Constraints are also imposed on the stability of rock walls as the depth of any rock fall will influence the resulting dimensions of the deposition hole. Further, the bottom of the deposition hole must be flat, the reference method to achieve a flat bottom is to install a bottom plate, see Section 5.3.6.

Thirteen experimental deposition holes were excavated to full depth by means of full-face down hole drilling at the Äspö HRL. Six of those deposition holes were located in the Prototype Repository. A presentation of the works and the results is given in /Andersson and Johansson 2002/. The objective was to demonstrate the technique for full-face down hole drilling of large vertical holes in granitic rock. The geometrical tolerances that was specified for the demonstration, differs slightly from those imposed by the buffer given in Table 2-2 in this document. However, the results from the demonstration showed that the drilling accuracy was acceptable. Moreover, the dimensions of the deposition holes in the Prototype Repository conform to the design premises imposed by the buffer.

The results from the Prototype Repository has been used for the purpose of estimating the installed buffer density at the initial state, see **Buffer production report** Section 6.1.4. The parameters used in the assessment are the as-built diameter and straightness of the deposition holes. The data used for estimating the installed buffer density are compiled in Appendix B.

SKB has initiated a feasibility study for developing the next generation of full-face down hole drill rigs. New technology will be introduced improving the already acceptable performance of the reference method. The number of deposition holes that will be drilled exceeds 6,000 and maintaining consistency in the drilling precision and accuracy is a key factor. Based on the demonstration some general conclusions can be drawn regarding key parameters and associated criteria that govern deposition hole straightness, diameter and cross-sectional area and their tolerances. It was found that two types of variability exists; variability relative to the scale of individual cross-sections and variability relative to the scale of individual deposition holes. The variability of the mean diameter for individual cross-sections in a deposition hole can be expected to be larger than the variability of the mean diameter for individual holes. It was also found that the theoretical centre point for individual cross-sections deviated with the depth of the deposition hole relative to a reference line between the theoretical centre point at the bottom of the hole and the theoretical centre point at the top. The maximum deviation is expected to be less than 10 mm, see Appendix B.

Control programme

There are suitable methods and instruments for inspecting the dimensions of deposition holes, e.g. laser scanning and geodetic methods. SKB will develop a procedure for verifying that the geometrical tolerances in deposition holes conform to the design premises. Primarily quality control and assurance procedures will be applied to inspect the positioning and alignment of the drill rig as well as the

conditions related to the drilling operation, e.g. checking cutter conditions. The resulting geometry after drilling will be inspected by one or a combination of the above measurement methods. A visual inspection of the completed deposition hole is also necessary in order to rule out the occurrence of spalling. In addition, SKB will customise a 3D modelling tool that can evaluate the relevant geometrical properties of the deposition holes. Any deposition hole that do not conform to the geometrical tolerances shall be rejected and backfilled.

5.3.3 Acceptable inflow

Acceptable inflow to deposition holes is stated in **Design premises long-term safety**. Further, according to **Design premises long-term safety**, grouting of deposition holes can be considered as long as the results are compatible with the long-term safety design premises. This implies that only vertical grouting holes which are fully located inside the planned deposition hole are acceptable. However, the current reference design does not consider grouting as a means to improve deposition holes with unacceptable inflows. Furthermore, it is foreseen that most of the planned positions for deposition holes having a potential for unacceptable inflows are likely to be screened out by the EFPC criterion, see Section 4.2.2.

SKB will develop a reference method for the selection of deposition hole positions with acceptable inflows. There are several parameters and associated criteria that have potential for predicting and verifying the performance of such a reference method. For example geo-hydrological characterisation can be carried out and inflows can be measured both in the pilot hole that will be drilled in the planned deposition hole position, and in the deposition hole after excavation.

Monitoring and control programmes

SKB will develop a procedure for verifying that the inflow in deposition holes will conform to the design premises. The planned locations of deposition holes will be decided in the detailed design. Input to adjusting or verifying the detailed design will be obtained within the framework of the observational method and the associated monitoring programme, i.e. by combining results from hydrogeological characterisation and geological modelling in different scales. The model that refers to deposition hole-scale comprises geological mapping of the deposition tunnel and hydrogeological characterisation of the investigation hole which is drilled at the planned location of the deposition hole.

Inflow criteria for pilot holes and deposition holes will be established based on the design premises stated in **Design premises long-term safety**. The design premises stipulate the maximum volume of water that is allowed to enter after the buffer is exposed to water until it is saturated. It is foreseen that the inflow to excavated deposition holes will be monitored until the completion of the installation of the buffer. Any deposition hole that do not conform to the design premise will be rejected and backfilled.

5.3.4 Methodology for accepting deposition holes on the basis of a discriminating fracture

In **Design premises long-term safety** it is stated that: *Deposition holes should be selected, as far as is reasonably possible, so that they do not have a potential for shear displacements larger than the canister can withstand. To achieve this, the EFPC criterion should be applied in selecting deposition hole positions.*

A report by /Cosgrove et al. 2006/ presents key properties and natural features of potentially discriminating structures, i.e. fractures and deformation zones. The term *deformation zone* is a collective term and includes a large spectrum of structures ranging from discrete brittle fractures through fracture zones to planar or sub-planar zones known as shear zones. The report concludes that it appears impossible to determine the actual size of fractures and deformation zones. However, the parameters that most likely reflect the size of fractures and deformation zones are identified. These parameters are:

- aperture,
- shear displacement,
- conductivity,
- deformation zone thickness.

The design premises stipulate that the EFPC criterion shall be applied in selecting deposition hole positions. The parameters and associated criteria for predicting and verifying a discriminating fracture or deformation zone intersecting a deposition hole remain to finalise. The recognition of a fracture or a deformation zone in more than one borehole or tunnel is one of the most important techniques available for detecting large fractures and deformation zones. Fracture infilling (either minerals or water) and wall rock alteration, both resulting from high fracture conductivity, are considered to be good indicators of fracture size. Moreover, infilling will often provide the fracture with a clear geophysical signature that enables its extent to be determined using geophysical methods. Hence the final choice of parameters and criteria are associated with the method used to identify such fractures or zones.

Monitoring and control programmes

SKB will develop a procedure for maximising the probability of detecting discriminating fractures and deformation zones. Primarily this includes designing the investigative probe holes that precede tunnel excavation. Geological mapping of tunnels and cores will provide detailed characterisation of the structures that intersect the tunnel. Before a deposition hole is excavated, a pilot hole is drilled. Core and borehole logging will provide information on the location and orientation of potentially discriminating structures. Any structure, whose extrapolation would intersect an adjacent deposition hole or tunnel, if the structure were sufficiently long, should be investigated. The reliability of the methods used for matching fractures and deformation zones between deposition holes and tunnels and or boreholes remains to be assessed. These methods include cross-hole correlation (exploiting kinematic indicators) and geophysical techniques such as borehole radar, which gives a good indication of the extent of the fracture into the rock around the hole. Hence application of the EFPC criterion requires results from geological characterisation, geophysical techniques and geological modelling. All deposition holes that do not conform to the EFPC criterion shall be rejected and backfilled.

5.3.5 Bevel in the upper part of the deposition hole

To limit the height of the deposition tunnel and still make it possible to turn the canister with its radiation protection into an upright position, a bevel is constructed in the upper part of the deposition hole. This upper part of the deposition hole is regarded as part of the deposition tunnel.

For the nominal tunnel height, the bevel must be 1.25 metres deep from the nominal tunnel floor and 1.6 metres long measured from the periphery of the deposition hole, see Figure 5-2. The reference method for construction of the bevel is wire sawing. The method has been demonstrated at the Äspö HRL in connection with tests of the rail-bound deposition machine.

5.3.6 Preparation of deposition holes

Before installation of the buffer preparation of the deposition hole is carried out. The preparation of deposition holes comprises, see **Buffer production line**, Section 5.4.3:

- removal of water and cleaning of the deposition hole,
- inspection of inflow to the deposition hole (see Section 5.3.3),
- inspection of potentially discriminating fractures intersecting the deposition hole (see Section 5.3.4),
- installation and inspection of the bottom plate,
- inspection to determine the dimensions of the deposition hole, i.e. radii and cross section as a function of depth, bottom inclination and total volume and location of the centre line (see Section 5.3.2).

The reference method for drilling deposition holes will not accomplish a flat bottom. In order to achieve a sufficiently flat bottom of the deposition hole a bottom plate is installed. The reference bottom plate consists of a low pH-cement concrete slab, and a lower and upper copper plate. At the installation three bolts are fixed in the rock at the bottom of the deposition hole. The lower copper plate is placed on top of the bolts. The bolts are then used to adjust the copper plate into a horizontal position. After that the concrete is poured through a hole in the centre of the lower copper plate. Finally the upper copper plate is placed in the deposition hole. It is provided with fasten devices which are pressed down into the fresh concrete through the hole in the lower plate. The upper plate is also provided with a border intended for auxiliary equipment for the installation of the buffer (see the **Buffer production report**, Section 5.4.3). The bottom plate is illustrated in Figure 5-3 which also contains its main data. A detailed description of the bottom plate is given in /Wimelius and Pusch 2008/.

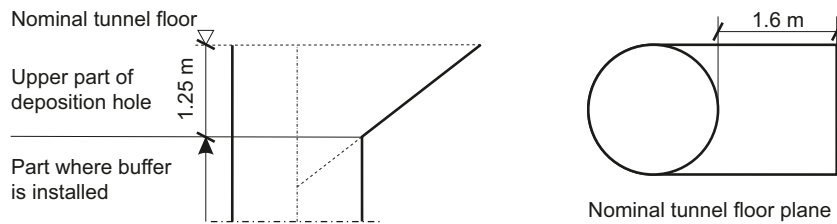
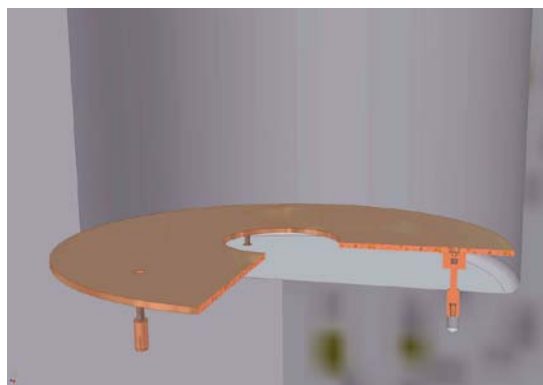

Figure 5-2. The nominal dimensions of the bevel. This upper part of the deposition hole is regarded as part of the deposition tunnel.

The reference bottom plate is based on available knowledge and conventional technique, SKB foresees no difficulties in manufacturing and installing it in conformity to the specification. However, SKB will study alternative ways to achieve a sufficiently flat bottom of the deposition hole.

After the bottom plate has been installed the geometry and position of the centre line of the deposition hole is measured in.



Lower copper plate resting on bolts fixed to the rock.

Thickness	20 mm
Diameter	1,710 mm
Hole diameter	450 mm
Nominal weight	382 kg

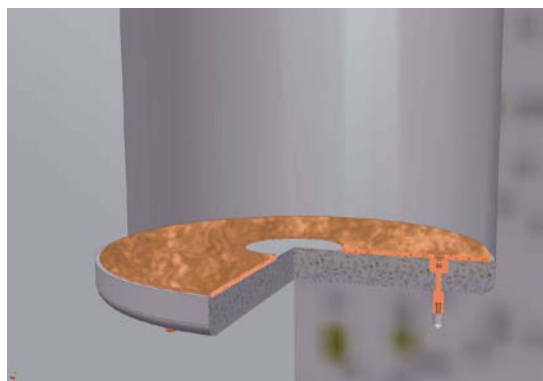

Concrete slab poured through the hole in the centre of the lower copper plate.

Thickness	150 mm
Nominal weight	650 kg
Concrete recipe	See Table 5-1

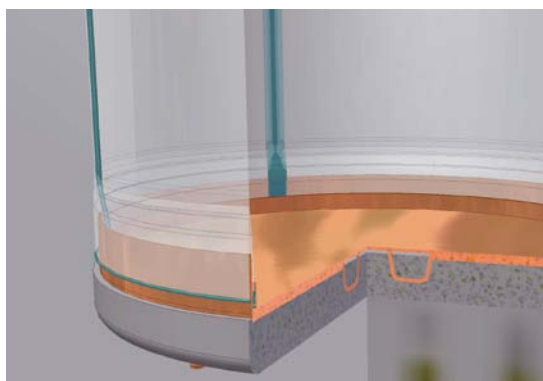

Upper copper plate with fastening devices and a border intended for auxiliary equipment for the installation of the buffer.

Thickness	~10 mm
Diameter	1,710 mm
Nominal weight	246 kg

Figure 5-3. The bottom plate in the deposition hole.

Table 5-1. Concrete recipe for the foundation of the bottom plate /Pusch and Ramqvist 2007/.

Components	Amount (kg/m ³ concrete)	Manufacturer
White cement	60	Aalborg Portland
Silica Fume	60	Elkem
Fine ground α -quartz M300	200	Sibelco
Fine ground cristobalite M6000	150	Sibelco
Superplasticizer Glenium® 51	4.375 (dry content)	Degussa
Granitic aggregates 0–4 mm	1,700	Jehanders grus
Water	244.27	local

5.4 Reference methods associated with other underground openings

The reference design for closure of main and transport tunnels, the ramp and shafts up to level –200 meter is to use clay blocks and pellets, i.e. the same reference design as for deposition tunnels. The design premises imposed by the closure are given in Table 2-5 and Section 2.3.3. Prior to the closure of the underground opening in question its conformity to the specified geometrical tolerances and acceptable inflow shall be verified. At this stage the reference methods used in the construction of deposition tunnels apply, although the design premises are less rigorous than those for deposition tunnels. The closure design will be further developed and it is most probable that requirements on the performance of reference methods used in the construction of the aforementioned underground openings can be relaxed.

6 Initial state of the underground openings

6.1 Introduction

The initial state of the underground openings refers to the properties of the underground openings at final installation of the buffer, backfill, closure or plugs. For the assessment of the long-term safety it shall be confirmed that the underground openings at the initial state conform to the design premises related to the functions in the final repository.

The presentation of the initial state comprises:

- a summary of the design premises related to the functions the underground openings shall have in the final repository together with the reference design for the Forsmark site and its conformity to the design premises, Section 6.2,
- an assessment of the geometry and other properties of importance for describing the initial state of the engineered barriers; at this stage it only considers deposition holes and deposition tunnels, Section 6.3,
- an assessment of uncertainty and risk that the initial state of the underground openings does not conform to the design premises, Section 6.4.

6.2 Reference design at the Forsmark site

The reference design for a KBS-3 repository at the Forsmark site has been developed in accordance with the design premises related to the functions of the underground openings in the final repository, Table 2-1. The applied design methodology and the essential engineering tasks are described in /SKB 2007/.

The repository facility layout in the reference design is based on the current knowledge of the site and adapted to the properties of the site as described in the current version of the SER /SKB 2009c/. The reference design and its conformity to the design premises were presented in Chapter 4 and are summarized in the following sections.

6.2.1 Repository depth and deposition areas

The repository depth shall be selected with respect to potential freezing, surface erosion and unintentional intrusion. Deposition areas and depth shall be selected with respect to hydrogeochemical conditions and the possibility to find large enough volumes to host the required number of deposition holes, Table 2-1. The determination of repository depth and the basis for the utilisation of deposition areas is presented in sections 4.1 and 4.2 and summarized below.

The repository depth, defined as the depth from the 0-level to the roof of the highest located deposition tunnel, shall according to SER be located at elevations ranging between –450 m and –500 m. The current reference design has been established with a minimum depth at elevation –457 metres and a maximum depth at elevation –470 metres. Thereby the risk for encountering water bearing fractures without significantly increasing the risk for spalling is reduced.

The layout and the utilisation of deposition areas are significantly influenced by the design premises for deposition holes, Table 2-1. The primary design constraints are: (1) deformations zones requiring a respect distance and (2) thermal properties of the rock mass as well as the approach used in the thermal dimensioning.

In the reference design potential deposition hole positions are not located within 100 m perpendicular distance from the boundaries of deterministic deformation zones that have a 3 km trace length or equivalent size.

The reference design layout is based on a fixed distance between deposition tunnels. The specified minimum centre-to-centre spacing is 40 m. Further, a minimum distance between deposition holes

of 6.0 m was a premise for the design. The minimum distance between deposition holes shall be determined with respect to the maximum allowed temperature in the buffer, Table 2-1. The thermal conductivity of the different rock domains was the basis for determining the distance between deposition holes. A conservative approach was employed and the minimum centre-to-centre spacing for the deposition holes is 6.0 m in RFM029 and 6.8 m in RFM045.

The justification of that the rock volumes selected for deposition areas in the reference design have favourable chemical conditions for deposition holes is found in /SKB 2009c/. The reference design does not verify favourable chemical conditions in individual deposition holes.

6.2.2 Deposition tunnels

The deposition tunnels shall be constructed so that the excavation-induced damage and the resulting connected transmissivity is limited (EDZ). Further, continuous grouting holes outside the tunnel perimeter and continuous grouting is not allowed, and only low pH cement may be used, Table 2-1.

The orientations of the deposition tunnels for the reference design shall be aligned within ± 30 degrees of the trend of the maximum horizontal stress, Section 4.4. In the reference design the deposition tunnels are aligned between 0 and 30 degree relative to the direction of the major horizontal stress. Assessments of stress concentrations in the rock mass surrounding the deposition tunnels indicate that they are below the current estimate of the spalling strength that was used for the reference design.

The need for grouting and rock reinforcement and the resulting amounts of engineered materials for the reference design is presented in Section 4.6. Only low pH cement is used in the reference design. The grouting methodology comprises three different cement-based grout mixes with a low pH. All cement mixes used in shotcrete support and for embedding various rock support elements are based on low pH cement.

6.2.3 Deposition holes

With respect to the functions in the final repository the deposition holes shall be placed so that the potential for shear displacements, water inflow and connected transmissivity are limited, Table 2-1.

The design premises for deposition holes that significantly influence the loss of potential deposition positions are; (1) minor deformation zones or discriminating structures or frequency of water-bearing fractures and (2) direction and magnitude of the major horizontal stress.

The location of structures with potential for shear displacements, i.e. discriminating fractures and deformation zones, cannot be determined deterministically at this stage, Section 4.2.2. While it is very likely that some deposition positions will be rejected due to discriminating fractures, it is extremely unlikely that this will impose a risk on the design premise to accommodate about 6,000 canisters /SKB 2009b/.

Very few additional deposition holes will be lost due to high inflows as most of these positions are likely to be screened out by the criterion for discriminating fractures, Section 4.2.2.

The major horizontal stress magnitude as well as a favourable orientation of deposition tunnels in the general direction of the major horizontal stress is of importance to reduce the occurrence of spalling (EDZ) in deposition holes. While there is high confidence in the design methodology utilised to assess the spalling potential for the reference design, there are uncertainty relative to the in situ stress conditions and the rock properties. This restricts the capability to model the extent of spalling and the associated change in transmissivity at this stage and additional investigations will be needed at the repository level to confirm the design assumptions.

Elevated stress magnitudes relative to the current reference design may result in realignment of deposition tunnels in the general direction of maximum horizontal stress. For the “unlikely maximum” stress model the tunnels must be aligned with the maximum horizontal stress to reduce the risk of spalling. The number of deposition holes in the reference design that may have to be rejected due to spalling is presented in Figure 4-3. It was assessed for the “unlikely maximum” stress model that aligning deposition tunnels with the maximum horizontal stress results in that approximately 100–200

deposition holes (out of 6,000) would sustain a spalling depth that exceeds the acceptable variation in deposition hole radius imposed by the buffer (also see **Buffer production report**, Section 6.1.4).

To summarise, the repository layout in the reference design has a gross capacity of 7,818 deposition hole positions which is sufficient for hosting the required 6,000 canisters provided that less than 23% (1,818) of the potential deposition positions are rejected.

6.3 Geometry and properties of importance for the initial state of the engineered barriers

The expected geometry and other properties of importance for the reliable installation of the engineered barriers according to specification and the extent of the EDZ will mainly depend on the performance of the methods for excavation (reference methods). The results that were used when determining the initial state of the engineered barriers are based on experiences and results presented in Chapter 5 and are summarized in the following sections.

6.3.1 Buffer and deposition holes

The buffer imposes design premises for the straightness, radius and maximum area of the deposition holes, Table 2-2 and Figure 2-1. In addition, the potential for occurrence of EDZ due to the excavation method must also be considered.

The results from drilling the deposition holes included in the Prototype Repository showed that the drilling accuracy is acceptable and that the dimensions of the deposition holes conforms to the current design premises, Section 5.3.2. Applying this experience to deposition holes excavated with a reamer head having the nominal diameter (1,750 mm), the most likely range of cross-sectional mean diameters would be found between 1,750 to 1,765 mm. However, for any occurrence of rock fall out or loosening of rock due to spalling it is required to improve the accuracy in drilling in direct proportion to the spalling depth (also see **Buffer production report**, Section 6.1.4).

The full-face down hole drilling method, which is the reference method, creates very little damage to the surrounding rock walls, Section 5.3.1. A reasonable value for the hydraulic conductivity of the EDZ, which is limited to a few centimetres in extent, is in the order of 10^{-10} m/s /Bäckblom 2008/. This magnitude is valid in rock conditions where spalling has not occurred.

The impact from occurrences of spalling on the installed buffer density and the possibility to adapt the installation of the buffer to the actual deposition hole geometry is discussed in the **Buffer production report**, Section 6.2.2.

6.3.2 Backfill and deposition tunnels

The backfill imposes design premises for the volume, maximum cross section, evenness of the tunnel floor and inflow to deposition tunnels, Table 2-3 and Figure 2-2. For the deposition tunnels EDZ created by the excavation method should be limited with respect to its contribution to the connected effective transmissivity.

The results from applying smooth-blasting techniques at the Äspö Hard Rock Laboratory showed that the reference method for excavation of deposition tunnels conform to the current design premises, Section 5.2.

Applying the experience from Äspö HRL to deposition tunnels in the reference design, the average excavated volume per round is assessed to be approximately 18% larger than the nominal volume. The rock surfaces in tunnels excavated by drill and blast will be rough and it cannot be excluded that small volumes of rock will protrude inside the nominal cross-section. However, this is easy to correct. Moreover, the smooth-blasting techniques resulted in blast-induced fractures that are dominantly radial in direction. Such fractures are not continuous along the axial direction of the tunnel over any significant distance.

SKB will develop a reference method that can provide a tunnel floor contour that conforms to the design premises imposed by the backfill, Section 5.2.3. A feasibility study of potential methods is ongoing in which smooth blasting techniques and wire sawing techniques, or combinations thereof, are assessed.

The open flowing fracture frequency at the repository level indicates a rock mass with very few open fractures and consequently that the inflows to deposition tunnels may be very low, Section 4.6.2. Cumulative density functions of transmissivity values in 20 m long sections, deformation zones excluded, indicates that on average less than 2% of the 20 m long sections will require grouting measures /SKB 2009c/.

6.4 Uncertainty and risk relative to the initial state

6.4.1 General basis

There are three general categories of uncertainties which may contribute to the risk that the initial state of the underground openings in the repository facility does not conform to the design premises. These uncertainties are related to:

1. site conditions (geohazards),
2. adequacy of design methodologies,
3. performance of reference methods.

The objective here is to assess the risk of nonconformity to the functions, geometry and other properties of importance for the final repository. The risk of rejecting underground openings for which the initial state conforms to the design premises is not analysed.

Uncertainties in the reference design and in the reference methods were discussed in Chapter 4 and Chapter 5, respectively.

The occurrences of geohazards were evaluated with qualitative risk analyses in /SKB 2009b/ in which potential consequences for the repository facility were assessed in terms of loss of deposition positions. The confidence in the design methodologies that were used to establish the reference design was also judged in /SKB 2009b/. The confidence in the adequacy of the applied design methodologies is acceptable or high, and its contribution to risk is considered to be negligible relative to the other two general categories of uncertainties, geohazards and hazards associated with reference methods.

The current risk assessment has emphasis on deposition tunnels and deposition holes. Only unwanted events (hazards) that would have widespread impact on the conformity of the underground openings to the design premises were considered. Local occurrences of unwanted events, e.g. human errors, were not evaluated. The reason is that localised events were not expected to alter the overall assessment of the initial state. Such events, in most cases, were considered possible to mitigate by means of quality control and assurance procedures and contingency measures and are therefore negligible for the initial state.

The current risk assessment is qualitative. Quantitative analyses using probability functions will be appropriate at a later stage when descriptions of uncertainties and the underlying data which are input to the assessment are well defined.

6.4.2 Geohazards, design methodologies and reference methods

The uncertainties in the site geological conditions, geohazards, and the consequences of these geohazards with respect to design are summarised in /SKB 2009b/. Table 6-1 provides a summary of the geohazards that were evaluated for the reference design and the general locations in the repository where the geohazard would be monitored.

In order to evaluate the risk for nonconformity to the design premises at the initial state, the first step is to assess the likelihood of occurrence of identified geohazards and hazards associated with reference methods.

Table 6-1. Catalogue of geohazards evaluated for the reference resign as well as the monitoring locations associated with the hazards. The table also includes the identifiers for the assessed hazards, a letter followed by an integer number, G1, H1, etc. (adapted from /SKB 2009b, Table 8-3/).

Geohazard: Geology	Monitoring location
(G1) Distribution of rock types	All excavations
(G2) Geological boundaries	All excavations
(G3) Frequency of large fractures	Deposition tunnels and deposition holes
(G4) New deformation zones between 1km and 3km trace length or equivalent size	All excavations
(G5) New deformation zones requiring respect distance	All excavations
(G6) Thickness of minor deformation zones (MDZ<1km)	All excavations
<hr/>	
Geohazard: Hydrogeology	Monitoring location
(H3) Frequency of discrete flowing fractures, with flows unsuitable for deposition holes or deposition tunnels	Deposition tunnels and deposition holes
<hr/>	
Geohazard: Rock mechanics/in situ stress	Monitoring location
(R1) Properties of the major and minor deformation zones	All excavations
(R2) Orientation of major horizontal stress	Skip shaft & ramp Deposition tunnels
(R3) Horizontal stress magnitudes	Skip shaft & ramp Deposition tunnels
<hr/>	
Geohazard: Thermal	Monitoring location
(T1) Geometrical distribution of thermal rock domains	Deposition tunnels and deposition holes
(T2) Rock containing mafic (Amphibolite) dykes (low T properties)	Deposition tunnels and deposition holes

The geohazards were grouped according to geology, hydrogeology, rock mechanics and in situ stress, and thermal properties. The likelihood of occurrence for geohazards was described using four descriptors, extremely unlikely, unlikely, likely and very likely. The descriptor aims at assessing the risk that the description of the site provided in the SDM /SKB 2008/ is incorrect. The descriptor *extremely unlikely* in the context of geohazards implies that there is simply no evidence from the site investigations to support the occurrence of the geohazard within the rock volume for the repository facility, while the descriptor *very likely* implies that the geohazard is expected to occur.

The likelihood of occurrence for hazards associated with the performance of reference methods were evaluated using the same four likelihood descriptors, extremely unlikely, unlikely, likely and very likely. The descriptor aims at assessing the risk for implications on the initial state of the underground openings located in deposition areas. The descriptor *extremely unlikely* implies that there is documented evidence that the reference method is reliable relative to the design premises, i.e. proven in operation or demonstrated functional, while the descriptor *very likely* implies that the hazard associated with the reference method is expected to occur, i.e. unacceptable performance.

Having identified the geohazards and the hazards associated with reference methods as well as their likelihood of occurrence, it remains to assess the risk of nonconformity of the underground openings to the design premises at the initial state. The initial state shall be evaluated by means of monitoring programmes and by implementing control programmes including control and quality assurance of the construction works, see Chapter 3. The reliability of the results from such programmes depends on the underlying technology, i.e. means and methods for investigation, characterisation, modelling and monitoring. The reliability were categorised based on the demonstrated performance, see Chapter 5. The qualitative confidence classes are defined in Table 6-2.

Table 6-2. Qualitative confidence classes are used for categorising the status of monitoring and control programmes which are employed to evaluate the initial state.

Confidence category	Status of monitoring and control programmes
High	Operational and/or successfully demonstrated
Acceptable	Conceptual with proven technology and/or demonstrated feasible
Low	Conceptual with new technology or unproven application

Hence the risk assessment of the initial state relative to nonconformity to the design premises is formed by the combination of two basic components; (1) likelihood of hazards relative to the geological site conditions (geohazards) or of hazards associated with the reference methods and (2) confidence in the results from the monitoring and control programmes that shall be employed to evaluate the initial state. Only one component is considered at a time, the other components are assumed to have the expected function.

6.4.3 Risk matrix

The results of the likelihood-confidence analyses are presented in a risk matrix, see Figure 6-1. The risk matrix provides means of ranking the hazards, visualize the results for each analysed design premise and identify unwanted events as a basis for deciding mitigation measures. For example, pointing out technical issues that need to be resolved in further developing the reference methods. For the risk matrix in Figure 6-1 only two categories of risk are identified:

1. Risk class N/A – the risks is considered *negligible* and/or *acceptable*, and
2. Risk class S/U – the risks is considered *significant* and/or *unacceptable*.

Risk category N/A reflects that the risk of accepting an underground opening with a non-conforming initial state is negligible or can be accepted because mitigation measures can be taken within the current reference design, or will be handled in the planned development of reference methods or in the planned development of the technology in the monitoring and control programmes.

Risk category S/U reflects that the risk of an initial state that does not conform to the design premises is imminent. This indicates that major changes may have to be imposed on the reference design or that the risk is not handled in the planned development of reference methods or in the planned development of the monitoring and control programmes. Risk category S/U need to be evaluated on an individual basis but indicates that:

- additional site information should be collected as soon as practical to resolve the uncertainty with the geohazard,
- the performance of the reference method is uncertain and that ongoing development need to consider improvements to the technology platform on which the reference method is based,
- the performance of the underlying technology in the monitoring and control programmes is not reliable and that ongoing development need to be accelerated or revised.

Likelihood of occurrence for identified hazards	Very likely	N/A	S/U	S/U
	Likely	N/A	N/A	S/U
	Unlikely	N/A	N/A	S/U
	Extremely Unlikely	N/A	N/A	N/A
		High	Acceptable	Low
Confidence in results from monitoring and control programmes				

Figure 6-1. Illustration of the risk matrix used for presenting the results of evaluating the likelihood-confidence analyses for the initial state.

6.4.4 Qualitative risk assessment of the initial state for repository depth and deposition areas

The relevant design premises for repository depth and deposition areas presented in Table 2-1 are repeated below for easy reference. The reference design and initial state is summarised in Section 6.2.1.

- *With respect to potential freezing of buffer and backfill, surface erosion and inadvertent human intrusion the depth should be considerable. Analyses in the SR-Can assessments corroborate that this is achieved by prescribing the minimum depth to be as specified for a KBS-3 repository i.e. at least 400 m.*
- *Reducing conditions: salinity – TDS limited; ionic strength – $[M^{2+}] > 1 \text{ mM}$; concentrations of K , HS^- Fe; limited; pH; $pH < 11$; avoid chloride corrosion – $pH > 4$ or $[Cl^-] < 3M$.*
- *The repository volumes and depth need to be selected where it is possible to find large volumes of rock fulfilling the specific requirements on deposition holes.*

The content in the last bullet point implies that the specific design premises for deposition holes shall be considered here. There are four primary design constraints concerning deposition holes that significantly influence the repository layout and the utilisation of deposition areas. (1) deformations zones requiring a respect distance, (2) minor deformation zones or discriminating structures or frequency of water-bearing fractures, (3) thermal properties of the rock mass and the approach used in the thermal dimensioning and (4) direction and magnitude of the major horizontal stress.

The uncertainty imposed on the initial state with respect to repository depth and deposition areas are associated with the geological site conditions and hence the potential impact of geohazards. Table 6-3 provides a summary of the likelihood of occurrence for the geohazards, the confidence classes for monitoring programmes and a short discussion about their current reliability. The results of the likelihood-confidence analysis are visualized in the risk matrix shown in Figure 6-2. Considering the occurrence and confidence in the reference methods none of the identified geohazards have a risk level which indicates that the repository depth and deposition areas at the initial state would not conform to the design premises.

For the geohazards R2, R3, R4 (Rock mechanics/in situ stress – orientation and magnitude of maximum horizontal stress) and T1 (Thermal – distribution of thermal rock domains), it was found that there is acceptable confidence in the results from monitoring programmes which are intended for their identification and characterisation. This indicates that the current status of the field methods can be considered as conceptual and that further development would be needed as well as demonstration of their reliability. The objective for further development would be to verify the assumptions in the reference design layout, i.e. the “most likely” stress model and that the orientation of the maximum horizontal stress does not vary more than ± 15 degrees and that the geometrical distribution of thermal rock domains does not deviate from the design values.

Table 6-3. Qualitative risk assessment showing likelihood of occurrence for the identified hazards and the confidence in detecting that the initial state of underground openings does not conform to the design premises listed in Section 6.4.4.

Geohazard ²	Likelihood of occurrence	Confidence in results	Current reliability
(G1) Distribution of rock types deviates from the design value	Unlikely	High	These geohazards can be identified and characterised with methods and techniques that were implemented during the site investigations. These methods and techniques are judged to produce reliable results, their performance is demonstrated and the degree of new technology involved in further development is not foreseen to introduce unforeseen uncertainties.
(G2) Geological boundaries deviates from those used in the design	Likely	High	
(G3) Frequency of large fractures exceeds the values predicted by the geological DFN Model	Extremely Unlikely	High	
(G4) New deformation zones between 1 km and 3 km long trace length or equivalent size	Unlikely	High	
(G5) New deformation zones requiring respect distance	Extremely Unlikely	High	
(G6) Thickness of minor deformation zones (MDZ<1km) exceeds the estimated values in SDM-Site	Unlikely	High	
(H3) Frequency of discrete flowing fractures, with flows unsuitable for deposition holes or deposition tunnels, below 400 m in FFM01 exceeds the hydrogeological DFN prediction used in the design	Extremely Unlikely	High	Stress measurements can be carried out in boreholes and the orientation of the stress field was evaluated using indicators such as observations of breakouts in boreholes /Martin 2007/. These methods are proven technology and judged to produce reliable results, however some degree of new technology and innovation are involved in developing suitable field methods.
(R1) Properties of the major and minor deformation zones deviates from the design value	Unlikely	High	
(R2) Orientation of maximum horizontal stress (σ_{hmax}) varies more than ± 15 degrees	Unlikely	Acceptable	
(R3) Horizontal stress magnitudes exceed "most-likely" model but not the "Unlikely maximum model"	Unlikely	Acceptable	
(R4) Horizontal stress magnitudes exceed the "Unlikely maximum" model	Extremely Unlikely	Acceptable	
(T1) Geometrical distribution of thermal rock domains deviates from the design value	Unlikely	Acceptable	

² Abbreviations used in Table 6-3 and Figure 6-2: (G1), (R1) etc. are identifiers, where (G) is short for Geology model, (H) Hydrogeological model, (R) Rock Mechanics/in situ Stress model and (T) Thermal model /SKB 2009b/.

Likelihood	Very likely			
	Likely	G2		
	Unlikely	G1, G4, G6, R1	R2, R3, T1	
	Extremely Unlikely	G3, G5, H3	R4	
		High	Acceptable	Low
Confidence in results from monitoring and control programmes				

Figure 6-2. Risk matrix showing likelihood of occurrence for the identified hazards and the confidence in detecting that the initial state of underground openings does not conform to the design premises listed in Section 6.4.4.

6.4.5 Qualitative risk assessment of the initial state for deposition tunnels

The relevant design premises presented in Section 2.3 are repeated below for easy reference. The reference design and expected initial state is summarised in Sections 6.2.2, and 6.3.2. The design premises associated with functions in the final repository are:

- Only low pH materials ($pH < 11$),
No continuous shotcrete,
Continuous grouting boreholes, outside tunnel perimeter should be avoided.
- Excavation induced damage should be limited and not result in a connected effective transmissivity, along a significant part (i.e. at least 20–30 m) of the disposal tunnel and averaged across the tunnel floor, higher than $10^{-8} \text{ m}^2/\text{s}$. Due to the preliminary nature of this criterion, its adequacy needs to be verified in SR-Site.

The design premises imposed by the backfill are:

- Based on current experiences the maximum distributed inflow into the deposition tunnel is set to be less than or equal to 1.7 l/min 100 m (based on 5 l/min in a 300 m long deposition tunnel) and the maximum point inflow less than or equal to 0.1 l/min.
- For each blast round the total volume between the rock wall contour and the nominal contour of the deposition tunnel shall be less than 30% of the nominal tunnel volume, see Figure 2-2.
- The maximum cross section shall be less than 35% larger than the nominal cross section, see Figure 2-2.
- To achieve a dependable backfill installation the tunnel floor must be even enough for the backfill installation equipment to drive on it.
- Underbreak is not allowed.
- Limited areas may be covered with construction materials. The areas must not extend over the full tunnel width.

The uncertainty imposed on the initial state with respect to deposition tunnels is associated with the potential impact of hazards related to the performance of the reference methods employed in the construction of the repository facility. Table 6-4 provides a summary of the likelihood of occurrence for the hazards, the confidence classes for monitoring and control programmes and a short discussion about their current reliability. The results of the likelihood-confidence analysis are visualized in the risk matrix shown in Figure 6-3. None of the identified hazards related to the reference methods have a risk level which indicates that the initial state would not conform to the design premises.

It was found that there is acceptable confidence in the results from the monitoring and control programmes which are intended for managing the hazard RM5 (need for characterisation or acceptance criteria for EDZ). This indicates that the current status of the field method can be considered as conceptual and that further development would be needed as well as demonstration of the reliability, see Section 5.2.1.

Table 6-4. Qualitative risk assessment showing likelihood of occurrence for the identified hazards and the confidence in detecting that the initial state of deposition tunnels does not conform to the design premises listed in Section 6.4.5.

Hazard ³	Likelihood of occurrence	Confidence in results	Current reliability
(RM1) The grouting methodology need to be further developed relative to the current performance and the specified inflows	Very Likely	High	There are uncertainties whether the performance of the grouting methodology is reliable relative to the very low inflows specified for the initial state. It is relatively straightforward to monitor the inflow to deposition tunnels and to evaluate the initial state as discussed in Section 5.2.4.
(RM2) The drilling and smooth blasting techniques need to be further developed relative to the current performance and the specified connected effective transmissivity from EDZ	Unlikely	High	The EDZ can be controlled by applying control programmes for drilling, charging and ignition. No specific method or combination of methods can yet be recommended for quantifying the connected effective transmissivity. The procedures and results from inspections, geological characterisation, geophysical techniques and geological modelling will be applied to verify that the damage in deposition tunnels conforms to the design premises. Although the basis is proven technology a certain degree of new technology and innovation is likely to be involved to develop the monitoring and control programmes, Section 5.2.1.
(RM5) Practical characterisation or acceptance criteria relative to EDZ need to be further developed	Likely	Acceptable	
(RM3) The drilling and smooth blasting techniques need to be further developed relative to the current performance and the specified geometrical tolerances for maximum cross-section, excavated volume and underbreak	Extremely Unlikely	High	The geometrical tolerances can be controlled by applying control programmes for drilling, charging and ignition. There are suitable methods and instruments for inspecting the geometry of deposition tunnels, e.g. laser scanning and geodetic methods. These methods and techniques are proven, their performance is demonstrated and the degree of new technology involved in further development is not foreseen to introduce unforeseen uncertainties, Section 5.2.2.
(RM4) The excavation technique for providing a sufficiently smooth tunnel floor contour need to be further developed relative to the current performance and the specified geometrical tolerances	Very Likely	High	There are uncertainties relative to the performance of the current conceptual reference method. There are suitable methods and instruments for inspecting the geometry of the deposition tunnel floor, e.g. laser scanning and geodetic methods. These methods and techniques are proven, their performance is demonstrated and the degree of new technology involved in further development is not foreseen to introduce unforeseen uncertainties, Section 5.2.2.

³ Abbreviations used in Table 6-4 and Figure 6-3: (RM) is short for Reference methods, see Chapter 5.

Likelihood	Very likely	RM1, RM4		
	Likely		RM5	
	Unlikely	RM2		
	Extremely Unlikely	RM3		
		High	Acceptable	Low
Confidence in results from monitoring and control programmes				

Figure 6-3. Risk matrix showing likelihood of occurrence for the identified hazards and confidence in detecting that the initial state of deposition tunnels does not conform to the design premises listed in Section 6.4.5.

6.4.6 Qualitative risk assessment of the initial state for deposition holes

The relevant design premises presented in Section 2.3 are repeated below for easy reference. The reference design and expected initial state of the deposition holes is summarized in Section 6.2.3 and 6.3.1. The design premises associated with functions in the final repository are:

- The buffer geometry (e.g. void spaces), water content and distances between deposition holes should be selected such that temperature in the buffer is $<100^{\circ}\text{C}$.
- Deposition holes should, as far as reasonably possible, be selected such that they do not have potential for shear larger than the canister can withstand. To achieve this, the EFPC criterion should be applied in selecting deposition hole positions.
- Fractures intersecting the deposition holes should have sufficiently low connected transmissivity (specific value cannot be given at this point). This condition is assumed to be fulfilled if the conditions regarding inflow to deposition holes are fulfilled.
- The total volume of water flowing into a deposition hole, for the time between when the buffer is exposed to inflowing water and saturation, should be limited to ensure that no more than 100 kg of the initially deposited buffer material is lost due to piping/erosion. This implies, according to the present knowledge, that this total volume of water flowing into an accepted deposition hole must be less than 150 m^3 .
- Before canister emplacement, the connected effective transmissivity integrated along the full length of the deposition hole wall and as averaged around the hole, must be less than $10^{-10}\text{ m}^2/\text{s}$

The design premises imposed by the buffer are:

- The diameter and height of the deposition hole shall allow sufficient room to accommodate the canister and buffer; the resulting nominal diameter is 1.75 m and the minimum depth is 6.68 m.
- The inclination over the part of the cross section where the bottom buffer block is placed shall be less than 1/1,750.
- In the part of the deposition hole where buffer is going to be deposited the diameter shall be at least 1.745 m. The nominal diameter is 1.75 m.
- From the buffer block on top of the canister to the bottom of the deposition hole the radius from a vertical line in the centre of the buffer rings shall be at least 840 mm.
- From the buffer block on top of the canister to the bottom of the deposition hole the radius from a vertical line in the centre of the buffer rings must not exceed 925 mm.
- In the part of the deposition hole where buffer is going to be deposited the maximum area in each horizontal cross section must not exceed the nominal cross section by more than 7.0%.

The uncertainties regarding the initial state of the deposition holes are related to geohazards as well as to hazards related to the performance of the reference methods. Table 6-5 provides a summary of the

likelihood of occurrence for the hazards, the confidence classes for investigation and monitoring and control programmes and a short discussion about their current reliability. The results of the likelihood-confidence analysis are visualized in the risk matrix shown in Figure 6-4. Considering the occurrence and confidence in the reference methods none of the identified geohazards have a risk level which indicates that the deposition holes at the initial state would not conform to the design premises.

It was found that there is acceptable confidence in the results from investigation and monitoring and control programmes which are intended for managing the hazards associated with shear movements (RM7), connected effective transmissivity (RM5, RM6) and geometrical tolerances (RM8). This indicates that the current status of the field methods can be considered as conceptual and that further development would be needed as well as demonstration of their reliability.

Table 6-5. Qualitative risk assessment showing likelihood of occurrence for the identified hazards and the confidence in detecting that the initial state of deposition holes does not conform to the design premises listed in Section 6.4.6.

Hazard ⁴	Likelihood of occurrence	Confidence in results	Current reliability
(T2) Rock containing mafic (Amphibolite) dykes (low thermal properties) occurs more frequently causing the thermal conductivity distribution in the up-scaled model to be less than the design value.	Unlikely	High	The hazard is associated with exclusion of potential deposition positions as well as verifying the distance between deposition holes. The effective way of ensuring that the thermal properties are determined correctly would be to combine geological characterisation with measurement techniques. These dark rock types are discrete in nature and can be identified with techniques that were implemented during the site investigations. The instruments and measurement techniques are judged to produce reliable results, their performance is demonstrated and the degree of new technology involved in the development programme is not foreseen to introduce new uncertainties. In addition, it is also possible to verify the reference design by in situ tests at repository depth.
(RM7) The current methodology for accepting or rejecting deposition holes on the basis of discriminating fractures need to be further developed relative to the current performance and the specified EFPC criterion.	Likely	Acceptable	No specific method or combination of methods can yet be recommended for quantifying the size of fractures or deformation zones. Results from investigations, geological characterisation, geophysical techniques and geological modelling will be required to apply the EFPC criterion. The tool box is considered to be conceptual and although the basis is proven technology a certain degree of new technology and innovation is likely to be involved to develop the monitoring programme, see Section 5.3.4.
(H3) Frequency of discrete flowing fractures, with flows unsuitable for deposition holes or deposition tunnels, below 400 m in FFM01 exceeds the hydrogeological DFN prediction used in the design.	Extremely Unlikely	High	It is foreseen that most of the planned positions for deposition holes having a potential for unacceptable inflows are likely to be screened out by the EFPC criterion. Combining results from hydrogeological characterisation and geological modelling in different scales will provide additional confidence in the selected deposition hole positions. Measuring inflow to deposition holes is relatively straightforward and to establish such a monitoring programme is not foreseen to introduce new uncertainties, Section 5.3.3.
(RM8) The current full face down-hole drilling technology and the methods to verify the performance need to be further developed relative to the specified geometrical tolerances.	Unlikely	Acceptable	The geometrical tolerances can be controlled by applying a control programme for the drilling operations. There are suitable methods and instruments for inspecting the dimensions of deposition holes, e.g. laser scanning and geodetic methods. However the current methods are considered to be conceptual and although the basis is proven technology a certain degree of new technology and innovation is likely to be involved to develop the control programme, Section 5.3.2.

⁴ Abbreviations used in Table 6-5 and 6-4: (H3), (RM7) etc. are identifiers, where (H) is short for Hydrogeological model and (T) Thermal model /SKB 2009b/. (RM) is short for Reference methods, see Chapter 5.

Hazard ⁴	Likelihood of occurrence	Confidence in results	Current reliability
(RM6) The current full face down-hole drilling technology and the methods to verify the performance need to be further developed relative to the specified connected effective transmissivity.	Extremely Unlikely	Acceptable	No specific method or combination of methods can yet be recommended for quantifying the connected effective transmissivity. It is assumed that the deposition holes conform to the design premises for connected effective transmissivity if they conform to the design premise for acceptable inflow. Results from inspections, geological characterisation, geophysical techniques and geological modelling will be applied to verify that the connected effective transmissivity in deposition holes conforms to the design premises. These methods are considered to be conceptual and although the bases is proven technology a certain degree of new technology and innovation is likely to be involved to develop the monitoring programme, Section 5.3.1.
(RM5) Practical characterisation or acceptance criteria relative to EDZ need to be further developed.	Likely	Acceptable	

Likelihood	Very likely			
	Likely		RM5, RM7	
	Unlikely	T2	RM8	
	Extremely Unlikely	H3	RM6	
		High	Acceptable	Low
		Confidence in results from monitoring and control programmes		

Figure 6-4. Risk matrix showing likelihood of occurrence for the identified hazards and confidence for detecting that the initial state of deposition holes does not conform to the design premises listed in Section 6.4.6.

References

SKB's (Svensk Kärnbränslehantering AB) publications can be found at www.skb.se/publications.

Backfill production report, SKB 2010. Design, production and initial state of the backfill and plug in deposition tunnels. SKB TR-10-16, Svensk Kärnbränslehantering AB.

Buffer production report, SKB 2010. Design, production and initial state of the buffer. SKB TR-10-15, Svensk Kärnbränslehantering AB.

Closure production report, SKB 2010. Design, production and initial state of the closure. SKB TR-10-17, Svensk Kärnbränslehantering AB.

Design premises long-term safety, SKB 2009. Design premises for a KBS-3V repository based on results from the safety assessment SR-Can and some subsequent analyses. SKB TR-09-22, Svensk Kärnbränslehantering AB

Repository production report, SKB 2010. Design and production of the KBS-3 repository. SKB TR-10-12, Svensk Kärnbränslehantering AB.

Andersson C, Johansson Å, 2002. Boring of full scale deposition holes at the Äspö Hard Rock Laboratory. Operational experiences including boring performance and a work time analysis. SKB TR-02-26, Svensk Kärnbränslehantering AB.

Bäckblom G, 2008. Excavation damage and disturbance in crystalline rock – results from experiments and analyses. SKB TR-08-08, Svensk Kärnbränslehantering AB.

Cosgrove J, Stanfors R, Röshoff K, 2006. Geological characteristics of deformation zones and a strategy for their detection in a repository. SKB R-06-39, Svensk Kärnbränslehantering AB.

EN 1997-1:2004. Eurocode 7. Geotechnical design – Part 1: General rules. Brussels: European Committee for Standardization.

Ericsson L O, Brinkhoff P, Gustafson G, Kvartsberg S, 2009. Hydraulic features of the Excavation Disturbed Zone – Laboratory investigations of samples taken from the Q- and S-tunnels at Äspö HRL. SKB R-09-45, Svensk Kärnbränslehantering AB.

Fransson Å, 2008. Grouting design based on characterization of the fractured rock. Presentation and demonstration of a methodology. SKB R-08-127, Svensk Kärnbränslehantering AB.

Funehag J, 2008. Injekteringen av TASS-tunneln. Delresultat t o m september 2008. SKB R-08-123, Svensk Kärnbränslehantering AB (in Swedish).

Hökmark H, Lönnqvist M, Kristensson O, Sundberg J, Hellström G, 2009. Strategy for thermal dimensioning of the final repository for spent nuclear fuel. SKB R-09-04, Svensk Kärnbränslehantering AB.

Jonsson M, Bäckström A, Feng Q, Berglund J, Johansson M, Mas Ivars D, Olsson M, 2009. Äspö Hard Rock Laboratory. Studies of factors that affect and controls the Excavation Damaged/Disturbed Zone. SKB R-09-17, Svensk Kärnbränslehantering AB.

Lindgren M, Pers K, Södergren Riggare S, 2009. Främmande material i slutförvaret Forsmark. Inventering för SR-Site. SKB P-09-07, Svensk Kärnbränslehantering AB (in Swedish).

Malmatorp J, Andersson C, Karlzén R, 2009. Bergtag i TASS-tunneln. Delresultat t o m september 2008. SKB R-08-122, Svensk Kärnbränslehantering AB (in Swedish).

Martin C D, 2005. Preliminary assessment of potential underground stability (wedge and spalling) at Forsmark, Simpevarp and Laxemar sites. SKB R-05-71, Svensk Kärnbränslehantering AB.

Martin C D, 2007. Quantifying in situ stress magnitudes and orientations for Forsmark. Forsmark stage 2.2. SKB R-07-26, Svensk Kärnbränslehantering AB.

Munier R, 2006. Using observations in deposition tunnels to avoid intersections with critical fractures in deposition holes. SKB R-06-54, Svensk Kärnbränslehantering AB.

- Munier R, 2007.** Demonstrating the efficiency of the EFPC criterion by means of sensitivity analyses. SKB R-06-115, Svensk Kärnbränslehantering AB.
- Munier R, 2010.** Full perimeter intersection criteria. Definitions and implementations in SR-Site . SKB TR-10-21, Svensk Kärnbränslehantering AB.
- Olsson M, Niklasson B, Wilson L, Andersson C, Christiansson R, 2004.** Äspö HRL. Experiences of blasting of the TASQ tunnel. SKB R-04-73, Svensk Kärnbränslehantering AB.
- Olsson M, Markström I, Pettersson A, Sträng M, 2009.** Examination of the Excavation Damaged Zone in the TASS tunnel, Äspö HRL. SKB R-09-39, Svensk Kärnbränslehantering AB.
- Peck R B, 1969.** Advantages and limitations of the observational method in applied soil mechanics. Geotechnique, 19, pp 171–187.
- Pusch R, Ramqvist G, 2007.** Borehole project – Final report of Phase 3. SKB R-07-58, Svensk Kärnbränslehantering AB.
- SKB, 2007.** Final repository facility. Underground design premises/D2. SKB R-07-33, Svensk Kärnbränslehantering AB.
- SKB, 2008.** Site description of Forsmark at completion of the site investigation phase. SDM-Site Forsmark. SKB TR-08-05, Svensk Kärnbränslehantering AB.
- SKB, 2009a.** Design premises for a KBS-3V repository based on results from the safety assessment SR-Can and some subsequent analyses. SKB TR-09-22, Svensk Kärnbränslehantering AB.
- SKB, 2009b.** Underground design Forsmark. Layout D2. SKB R-08-116, Svensk Kärnbränslehantering AB.
- SKB, 2009c.** Site engineering report Forsmark. Guidelines for underground design. Step D2. SKB R-08-83, Svensk Kärnbränslehantering AB.
- SKB, 2010.** Ramprogram för detaljundersökningar vid uppförande och drift av slutförvar för använt kärnbränsle. SKB R-10-08, Svensk Kärnbränslehantering AB.
- Wimelius H, Pusch R, 2008.** Buffer protection in the installation phase. SKB R-08-137, Svensk Kärnbränslehantering AB.

Tabulation of data from measurements of as-built volumes in the tunnel excavated by means of smooth-blasting techniques at the Äspö Hard Rock Laboratory

For further details see Section 5.2.2

The following definition apply. The cross-sectional area of the experimental tunnel, 18.9 m², is the *nominal cross-section*.

The experimental data are presented in Table A-1. The quantified cross-sections are those actually measured and refer to the beginning and end of the blasting rounds, respectively. The round depths are the actual measured and not the planned. The excavated volumes above the nominal were calculated from surveyed tunnel profiles with one metre spacing. The aim was to position the drill at the nominal tunnel profile at the start of the contour holes. The look-out angle, which defines the theoretical completion of the contour hole, was 200 mm and 250 mm as shown in Table A-1. The look-out angle creates an additional volume outside the nominal that gradually increases along the length of a blast round. This space will be occupied by the drilling equipment when drilling is ongoing for the next blasting round.

Table A-1. Experimental data based on /Malmtorp et al. 2009/.

Blasting round	Actual cross-sectional area start [m ²]	Actual cross-sectional area end [m ²]	Actual depth of blast round [m]	Excavated volume above the nominal [m ³]
6	–	21.0	4.1	41.8
7	20.5	24.0	4.1	Look-out angle were 200 mm
8	21.3	22.6	4	
9	21.0	23.4	4.6	46.6
10	20.5	22.8	4.6	Look-out angle were 250 mm
11	21.2	22.4	3.6	
12	21.5	–	3.0	
Mean	21.0	22.9		
Key parameters	Overall mean = 22.0		Sum = 27.9	Average cross-section (18.9 x 27.9+41.8+46.6)/27.9 = 22.1 m ²

Tabulation of data from measurements of cross-sectional centre points and diameters in 6 deposition holes drilled at the Prototype Repository at the Äspö Hard Rock Laboratory

For further details see Section 5.3.2

In the experimental trial, at every 400 mm of drilling the theoretical centre point was determined for the cross-section in question. This enabled calculation of its deviation. Deviation was defined as the horizontal distance between the theoretical centre point of the cross-section and a reference line between the theoretical centre point at the bottom of the hole and the theoretical centre point at the top. The calculated deviation in cross-sectional centre points can be regarded as an estimation of the straightness of the deposition hole. The maximum deviation in the deposition holes can be assessed to be less than 10 mm as shown in Figure B-1.

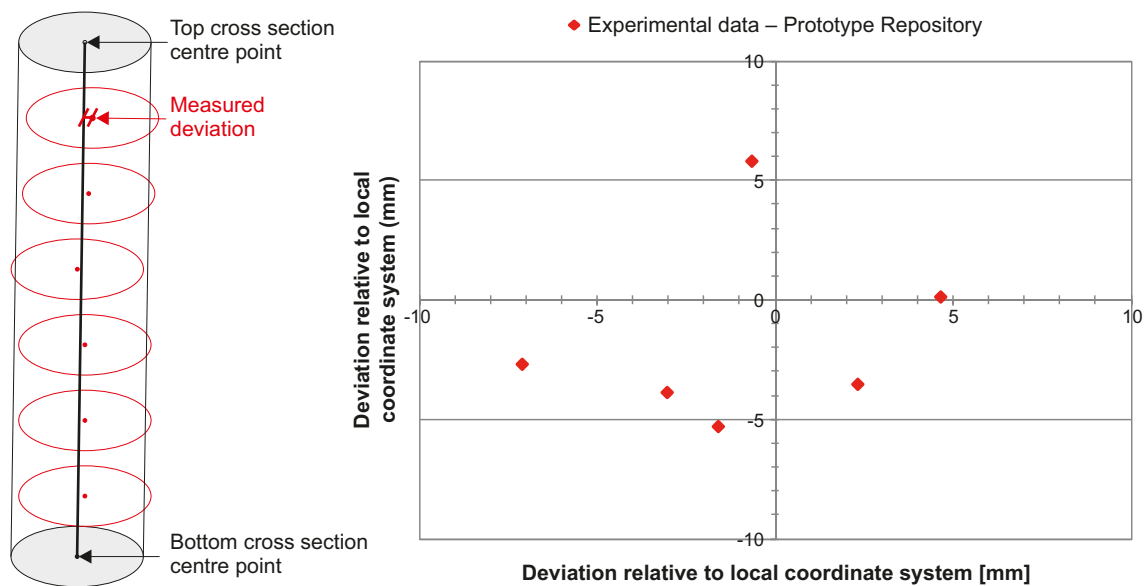

Figure B-1. Deviation was defined as the horizontal distance between the theoretical centre point of the cross-section in question and a reference line between the theoretical centre point at the bottom of the hole and the theoretical centre point at the top. This measure can be regarded as an estimation of the straightness of the deposition hole. Calculation results showing the maximum deviation value are plotted for each deposition hole.

Table B-1. Measured diameters in 6 Deposition holes drilled for the Prototype Repository

Borehole DA3587G01 (hole No. 5)					Borehole DA3581G01 (hole No. 6)				
Depth (m)	Diameter (mm)				Depth (m)	Diameter (mm)			
	1-4	2-5	3-6	mean		1-4	2-5	3-6	mean
0.00	1,758	1,767	1,752	1,759	0.00	1,764	1,759	1,759	1,761
0.40	1,758	1,752	1,767	1,759	0.40	1,759	1,754	1,754	1,756
0.80	1,748	1,757	1,757	1,754	0.80	1,759	1,754	1,759	1,757
1.20	1,758	1,762	1,757	1,759	1.20	1,764	1,759	1,759	1,761
1.60	1,758	1,762	1,757	1,759	1.60	1,759	1,764	1,759	1,761
2.00	1,758	1,762	1,762	1,761	2.00	1,759	1,759	1,754	1,757
2.40	1,763	1,767	1,757	1,762	2.40	1,759	1,759	1,754	1,757
2.80	1,758	1,762	1,757	1,759	2.80	1,759	1,759	1,754	1,757
3.20	1,763	1,762	1,757	1,761	3.20	1,759	1,759	1,764	1,761
3.60	1,758	1,762	1,757	1,759	3.60	1,759	1,759	1,754	1,757
4.00	1,758	1,762	1,762	1,761	4.00	1,759	1,759	1,759	1,759
4.40	1,758	1,767	1,762	1,762	4.40	1,764	1,764	1,759	1,762
4.80	1,758	1,762	1,757	1,759	4.80	1,759	1,759	1,759	1,759
5.20	1,758	1,757	1,757	1,757	5.20	1,759	1,759	1,759	1,759
5.60	1,758	1,762	1,757	1,759	5.60	1,764	1,764	1,759	1,762
6.00	1,763	1,762	1,757	1,761	6.00	1,764	1,759	1,759	1,761
6.40	1,758	1,762	1,757	1,759	6.40	1,759	1,759	1,759	1,759
6.80	1,758	1,757	1,757	1,757	6.80	1,759	1,759	1,759	1,759
7.20	1,758	1,767	1,757	1,761	7.20	1,759	1,759	1,759	1,759
7.60	1,758	1,767	1,762	1,762	7.60	1,759	1,759	1,759	1,759
8.00	1,758	1,757	1,757	1,757	8.00	1,764	1,759	1,759	1,761
8.15	1,758	1,762	1,757	1,759	8.15	1,754	1,759	1,754	1,756
Mean diam for the borehole				1,759	Mean diam for the borehole				1,759
Borehole DA3575G01 (hole No. 7)					Borehole DA3569G01 (hole No. 8)				
Depth (m)	Diameter (mm)				Depth (m)	Diameter (mm)			
	1-4	2-5	3-6	mean		1-4	2-5	3-6	mean
0.00	1,763	1,763	1,757	1,761	0.00	1,759	1,763	1,761	1,761
0.40	1,758	1,763	1,757	1,759	0.40	1,764	1,763	1,761	1,763
0.80	1,758	1,763	1,752	1,758	0.80	1,759	1,763	1,756	1,759
1.20	1,758	1,763	1,752	1,758	1.20	1,759	1,768	1,761	1,763
1.60	1,763	1,763	1,757	1,761	1.60	1,759	1,763	1,761	1,761
2.00	1,758	1,758	1,757	1,758	2.00	1,754	1,763	1,761	1,759
2.40	1,763	1,763	1,757	1,761	2.40	1,759	1,763	1,756	1,759
2.80	1,763	1,763	1,757	1,761	2.80	1,764	1,763	1,756	1,761
3.20	1,758	1,763	1,762	1,761	3.20	1,759	1,763	1,761	1,761
3.60	1,758	1,768	1,757	1,761	3.60	1,759	1,768	1,761	1,763
4.00	1,763	1,763	1,752	1,759	4.00	1,759	1,763	1,756	1,759
4.40	1,758	1,758	1,757	1,758	4.40	1,759	1,763	1,761	1,761
4.80	1,758	1,758	1,762	1,759	4.80	1,759	1,763	1,756	1,759
5.20	1,763	1,763	1,762	1,763	5.20	1,759	1,768	1,756	1,761
5.60	1,758	1,763	1,757	1,759	5.60	1,759	1,768	1,756	1,761
6.00	1,763	1,763	1,757	1,761	6.00	1,759	1,768	1,761	1,763
6.40	1,758	1,763	1,762	1,761	6.40	1,759	1,768	1,756	1,761
6.80	1,758	1,763	1,757	1,759	6.80	1,759	1,768	1,756	1,761
7.20	1,763	1,763	1,757	1,761	7.20	1,764	1,763	1,751	1,759
7.60	1,758	1,763	1,762	1,761	7.60	1,759	1,763	1,761	1,761
8.00	1,763	1,763	1,757	1,761	8.00	1,759	1,763	1,756	1,759
8.15	1,758	1,763	1,757	1,759	8.15	1,754	1,758	1,751	1,754
Mean diam for the borehole				1,760	Mean diam for the borehole				1,760

Table B-1. Measured diameters in 6 Deposition holes drilled for the Prototype Repository (continued)

Borehole DA3551G01 (hole No. 9)					Borehole DA3545G01 (hole No. 10)				
Depth (m)	Diameter (mm)				Depth (m)	Diameter (mm)			
	1-4	2-5	3-6	mean		1-4	2-5	3-6	mean
0.00	1,752	1,761	1,762	1,758	0.00	1,755	1,757	1,756	1,756
0.40	1,752	1,766	1,757	1,758	0.40	1,760	1,762	1,756	1,759
0.80	1,752	1,756	1,762	1,757	0.80	1,760	1,762	1,756	1,759
1.20	1,752	1,761	1,767	1,760	1.20	1,760	1,757	1,756	1,758
1.60	1,757	1,766	1,767	1,763	1.60	1,760	1,757	1,756	1,758
2.00	1,747	1,756	1,767	1,757	2.00	1,755	1,762	1,756	1,758
2.40	1,747	1,766	1,767	1,760	2.40	1,765	1,752	1,761	1,759
2.80	1,747	1,766	1,767	1,760	2.80	1,765	1,767	1,756	1,763
3.20	1,742	1,771	1,777	1,763	3.20	1,765	1,747	1,756	1,756
3.60	1,747	1,766	1,767	1,760	3.60	1,765	1,767	1,756	1,763
4.00	1,747	1,766	1,767	1,760	4.00	1,765	1,757	1,756	1,759
4.40	1,742	1,771	1,762	1,758	4.40	1,770	1,762	1,761	1,764
4.80	1,747	1,771	1,767	1,762	4.80	1,765	1,757	1,761	1,761
5.20	1,747	1,766	1,772	1,762	5.20	1,765	1,757	1,756	1,759
5.60	1,737	1,771	1,767	1,758	5.60	1,765	1,762	1,756	1,761
6.00	1,742	1,781	1,767	1,763	6.00	1,760	1,757	1,751	1,756
6.40	1,742	1,771	1,777	1,763	6.40	1,765	1,752	1,756	1,758
6.80	1,742	1,771	1,767	1,760	6.80	1,765	1,757	1,751	1,758
7.20	1,737	1,766	1,767	1,757	7.20	1,770	1,762	1,756	1,763
7.60	1,742	1,771	1,772	1,762	7.60	1,770	1,762	1,756	1,763
8.00	1,747	1,766	1,772	1,762	8.00	1,765	1,757	1,751	1,758
8.15	1,742	1,761	1,767	1,757	8.15	1,765	1,757	1,751	1,758
Mean diam for the borehole				1,760	Mean diam for the borehole				1,759